

*Original operating instructions*

# **RT-UG 5000**

*Pressurisation equipment  
with twin compressor system*



# Contents

Ordering data	4
Technical specifications	4
Scope of supply	5
Marking	5
Symbols used	5
Legal provisions	6
Liability	6
Warranty	6
General	6
Conventional use	7
Safety instructions	7
For the safety of persons in charge	7
Operator	7
Qualified employees	7
Staff qualification	7
General safety instructions	8
Safety instructions for electrical works	9
Safety instructions for works on compressed air lines and pressure tanks	9
Safety instructions for working with drying agents	9
Safety devices	10
Remaining dangers	10
Service conditions	10
Temperatures	10
Ambient conditions	10
Installation conditions	10
Transportation	11
Storage	11
General information on storage	11
Functionality of pressurization system RT-UG 5000	11
Product description	12
Product marking, connection and operation RT-UG 5000	12
Instrument panel	13
Pressurised air supply, storage, drying and monitoring	14
Multifunctional Relay MFR	16
Electrics	17
Mounting	18
Setting up the system RT-UG 5000	18
Connect the condensate discharge hose	18
Mounting of the switch box	18
Mounting of the compressors	19
Mounting the compressors	19
Connecting the compressors	19
Connecting the monitoring system	20
Connecting the signal output „High pressure alarm”	20
Electrical connection	21
Operating voltage AC	21
Operation of the Compressor Monitoring Unit ACS	22
Start the ACS	22
Operating the ACS	22
Read ACS values	22
Read MFR values	24
Reset maintenance counter	24
Poll MFR alarm conditions	24
Test of MFR alarmdisplay	24
Deactivating humidity monitoring of the MFR	24
Read MFR settings	25
Read MFR info	25
Read display info	25
Service mode	26
ACS settings	26
MFR settings	26
ACS set „top value”	27
Set up Air Flow Value	27

<b>Operation of multifunctional relay MFR</b> .....	<b>28</b>
<b>Meaning of the LEDs</b> .....	<b>28</b>
Normal operation .....	28
Alarms .....	28
Buttons .....	28
Fuses .....	28
<b>Start-up</b> .....	<b>30</b>
<b>Before start-up</b> .....	<b>30</b>
<b>Set the equipment into operation / charge equipment</b> .....	<b>30</b>
<b>Function testing / setting of components</b> .....	<b>32</b>
<b>Check and set reference value motor protective switch back-up fuse</b> .....	<b>32</b>
<b>Check and set the pressure switch "high pressure"</b> .....	<b>33</b>
<b>Check and set pressure monitor</b> .....	<b>34</b>
<b>Check and set pressure limiting valve</b> .....	<b>35</b>
<b>Check humidity monitoring</b> .....	<b>36</b>
<b>Check clock pulse air dryer change-over</b> .....	<b>37</b>
<b>Check humidity content of output air</b> .....	<b>38</b>
<b>Operation On - Off</b> .....	<b>38</b>
<b>Connection equipment pneumatics</b> .....	<b>38</b>
<b>Pneumatic connection to air consumers</b> .....	<b>38</b>
<b>Normal mode</b> .....	<b>38</b>
<b>Emergency mode</b> .....	<b>39</b>
<b>Shut down operation</b> .....	<b>39</b>
<b>General comments</b> .....	<b>40</b>
<b>Maintenance</b> .....	<b>40</b>
<b>Cleaning or changing compressor air intake filters</b> .....	<b>40</b>
<b>Cleaning coolers for the compressor exhaust air</b> .....	<b>41</b>
<b>Change micro filter element of micro filter</b> .....	<b>41</b>
<b>Maintenance of air dryers</b> .....	<b>42</b>
<b>Causes and remedy of faults</b> .....	<b>44</b>
<b>What to do after "humidity fault"?</b> .....	<b>45</b>
<b>Replacement parts</b> .....	<b>48</b>
Display, operation .....	48
Drying agent container .....	50
Compressor PK 145/2 .....	50
Micro filter .....	51
Electrics .....	51
<b>Plans</b> .....	<b>52</b>
Equipment lists pneumatics RT-UG 5000 .....	52
Pneumatics diagram RT-UG 5000, no. 074664.000 .....	53
Equipment list electrics RT-UG 5000 .....	54
Circuit diagram RT-UG 5000, no. 074665.000 .....	55
Equipment list electrics RT-UG 5000 .....	56
Wiring diagram RT-UG 5000, no. 074666.000 .....	57
<b>Disposal</b> .....	<b>58</b>
<b>EC Declaration of Conformity</b> .....	<b>60</b>



### Important!

It is imperative to read and observe the safety instructions prior to start up!

## Technical specifications

<b>Pressurization System Type</b>	<b>RT-UG 5000</b>
Output power (with cable pressure set at 1,5 bar)	5000 NI/h
Number of consumer load connection point	1
Compressor set with two compressors PK 145/2	Number of cylinders 4
Engine RPM	1425 min <sup>-1</sup>
Operating voltage	230/400 V, 3 Phases
Frequency	50 Hz
Current consumption of both compressors	approx. 10,0 A
Working pressure of compressors	max. 7,0 bar
Opening pressure safety valve "compressor"	7,0 bar ± 10 %
Working pressure On-Off	3,5 to 5,0 bar
Opening pressure safety valve "high-pressure"	7,0 bar
Output pressure is adjustable (customised)	0 - 1,5 bar
Opening pressure safety valve "output pressure"	1,7 bar ± 10 %
Relative humidity output air (typical)	≤ 1,5 %
Regeneration air mass	approx. 3300 l/h ±10 %
Regeneration time drying agent container	120 s
Content air storage tank	2 x 40 l
Ambient temperature limit	+1 °C bis +40 °C
Ambient humidity limit	0 .. 90 % rel. humidity, non condensing
Signal voltage	48 or 60 V DC
Signal LEDs (standard)	Operation (DC) Fault (A)
Signal output (floating)	Fault (Accumulative A) Accumulative A = F, M
Workplace-related emission value	79 dB(A)
Measurement uncertainty dB(A)	± 2,3 dB(A)
Measuring system	DIN 45635 section 1
Measuring conditions	in the room
Measurements: Width x Depth x Height	700 x 630 x 1300 mm
Weight	approx. 195 kg

All pressure specifications are seen as gauge pressure specifications.

## Ordering data

Pressurization system RT-UG 5000

Order no. 072588.200

## Scope of supply

- Pressurization system RT-UG 5000, consisting of
  - 1 solid metal cabinet with the following mounting parts:
    - 2 compressors, separate for self installation
    - 2 air storage tanks of 40 l each
    - 1 air dryer system
    - various control, measuring and display elements
- Operating instruction
- CE Declaration of Conformity

## Marking

The pressurization systems are clearly marked by the content of the name plate including technical specifications and manufacturer's instructions. The name plate is found on the bottom right of the front panel (see pages 12/13).

Accordance with the applicable regulations is validated with the enclosed CE Declaration of Conformity (see the back of this operating instruction).

**LANCIER**  
Monitoring

Name : Pressurisation System  
 Type : RT-UG 5000  
 Serial number : as delivery note  
 Year of manufacture : 20xx  
 Operating voltage : 230/400 V, 50 Hz  
 Power consumption : max. 10 A

**LANCIER Monitoring GmbH,**  
 Gustav-Stresemann-Weg 11, D-48155 Münster



## Symbols used



**Attention Danger!**

This symbol warns of the health risks up to threatening injuries or death.



**Warning Danger of electric voltage!**

This symbol warns of the health risks up to threatening injuries or death caused by electric voltage.



**Turn power off!**

This symbol indicates that electrical components and systems must be disconnected prior to maintenance and repair work and also protected against resetting.



**Wear protective gloves!**

This symbol indicates that protective gloves must be worn during the works described.



**Wear safety glasses!**

This symbol indicates that safety glasses must be worn during the works described.



**Note for disposal!**

This symbol indicates that the resulting waste must be disposed ecologically and not become domestic waste.

## Legal provisions

### Liability

The information, data and references specified in this operating instruction were up-to-date on the day of print. Claims on systems already supplied can only be asserted conditionally from details, illustrations and descriptions.

LANCIER Monitoring GmbH assume no liability for damages and disruption of operations, which may result from:

- Non compliant use
- Arbitrary change to the equipment
- Improper work on and with the equipment
- Operating and setting error
- Disregarding existing standards, directives and accident prevention regulations
- Disregarding operating instruction

### Warranty

- Warranty takes place according to the general terms and conditions of LANCIER Monitoring GmbH.
- Warranty claims must be asserted to LANCIER Monitoring GmbH immediately upon detecting a fault or failure.
- The warranty terminates in all cases where also no liability claims can be asserted.

## General

This operating instruction is valid for the pressurization system RT-UG 5000 and its variants.

It shall help you to get to know the product and contains important information to operate the system safely, properly and economically, to make use of the range of functions, to lessen repair costs and down times, as well as to increase the reliability and service life of the equipment.

Furthermore, this manual will enable you to carry out maintenance and repair work on the pressurization system yourself for daily use.

It contains safety instructions, which must be observed.

During operation, other instructions must be observed if necessary for components to be installed optionally, such as flow meter, distribution devices etc.

The operating instruction is supplemented with instructions on the basis of current national regulations on accident prevention and environmental protection.

The operating instruction must always be on hand at the point where the equipment is used, complete and in legible condition.



**The operating instruction shall be read and applied by anyone assigned to work with/on the system, e.g. during**

- **operation, including installation, setting up, fault repair in the production flow, removal of production waste, care, disposal of materials.**
- **Maintenance (servicing, inspection, repair)**
- **Transportation**

Besides the instruction manual and the accident prevention regulations applicable in the country and site of use, the recognised specialised rules for safe and professional work shall also be observed.

This documentation was compiled with the utmost diligence, taking the existing regulations into consideration. However, variations cannot be excluded. LANCIER Monitoring reserves the right to make technical modifications to the pressurization system without prior notification and assumes no legal responsibility or liability for damages, which may arise.

Any necessary changes are promptly incorporated into the current versions of this operating instruction.

## Conventional use

Pressurization system RT-UG 5000

- is solely intended for use as a system to compress and dry purified air, to supply cables or cooling water lines.
- is solely fit for compressing and drying purified air to be supplied to cables and cooling water lines.
- shall only be used for the purposes validated by LANCIER Monitoring.
- shall only be operated under the conditions stipulated in this operating instruction.
- shall only be operated with the settings and variants stipulated in this operating instruction.

The automatic operation of the system permits unsupervised, steady use.

**Any other use is not classed as conventional. The manufacturer takes no responsibility for any resulting damages. The operator alone bears the risks!**

Arbitrary changes in design or system rebuild are prohibited without the written consent of the manufacturer, as are modifications and interventions in the control programme, the compressors and settings of the drying process, as well as the pressures used.

Compliance with the stipulated operating, servicing and repair conditions also form part of conventional use.

## Safety instructions



### Important!

**It is imperative to read and observe the safety instructions prior to start up.  
The operating instruction must always be stored within reach.**

## For the safety of persons in charge

### Operator

Operator is any natural or legal person, who uses the equipment or on whose instructions the equipment is used.

The operator or his safety officer must guarantee, that

- all relevant regulations, references and laws are adhered to.
- only qualified employees work on and with the equipment
- employees have the operating instruction available during all works and abide by this.
- non-qualified employees are forbidden from working on and with the equipment, as well as installation and servicing. The necessary accident prevention and safety instructions must be adhered to.

### Qualified employees

Qualified employees are persons who are authorised by the person in charge for equipment safety based on their training, experience, instruction and knowledge on relevant standards and provisions, accident prevention regulations and operating conditions, to carry out operations required and be able to identify and prevent possible dangers.

### Staff qualification

Operations	Briefed person	Briefed person with technical training	Electro specialists
Initial commissioning	-	-	✓
Operation	✓	✓	✓
Fault repair			
- mechanic	-	✓	✓
- electrical	-	-	✓
Cleaning	✓	✓	✓
Servicing	-	✓	✓
Work on the electrics	-	-	✓
Packaging / transportation	✓	✓	✓



## General safety instructions

These safety instructions are not exhaustive. For questions and problems please contact the customer service department at LANCIER Monitoring.

- Always store the operating instruction within reach!



### Accident prevention! Risk of damage!

- The system is classed as state-of-the-art at the time of start-up and essentially reliable.
- The system must only be operated in technically-sound condition, with the protective devices enabled. The operating instruction should be observed properly, conscious of risks and safety.
- The area surrounding the system shall be kept clean and tidy. Contaminations and obstructions of the equipment's function, as well as restrictions in the freedom of movement of operating personnel, can lead to operational faults and accidents.
- The operating personnel are obliged to check the equipment and its function groups at least once a week for damages and faults. Changes, including those to the operating behaviour, which affect the safety, shall be reported and corrected immediately.
- Risks for persons, the equipment itself and for other material assets emanate from the equipment, if
  - non-qualified personnel work on and with the equipment
  - the equipment is not used conventionally
  - the equipment is set or connected incorrectly
- The equipment must be set and fitted so that it fulfils its function for proper and conventional use in fail-safe operation, representing no danger.
- Suitable measures must be taken so that an equipment breakdown does not result in any damage to persons or property.
- Specific faults which may compromise safety have to be corrected immediately!
- The pressurization system RT-UG 5000 must only be installed, operated, serviced and repaired by persons who have been briefed on the potential dangers.
- Refittings, modifications or rebuilds of the equipment are strictly prohibited! Always consult LANCIER Monitoring in any case.
- The electricity supply and other works/repairs to the system's electrical fittings must only be carried out by electric specialists.
- Keep all safety instructions and danger warnings on the system in legible condition!
- Do not undo or open screw connections and tank, before the system is depressurised. Open to bleed the safety valve "high-pressure" **(18)**
- Do not operate, service or repair the system with wet hands!
- Do not touch the drying agent with wet hands - heat build-up!
- Do not open the drying agent container before it is depressurised!
- Adhere to the terms stipulated or specified in the operating instruction for periodic inspections/maintenance.
- After any maintenance and repair work check all unfastened screw connections.
- Disconnect the operating voltage main switch prior to maintenance and repair works.
- After connecting electricity: Take caution with live components!
- For works on opened system: Take caution with heated components!
- Only use original LANCIER Monitoring replacement parts!



### Accident prevention!

- Use personal protective equipment and wear close-fitting work clothes and work safety footwear!
- When using drying agents wear work gloves and safety glasses!
- Always tie back long hair, do not wear loose clothing or jewellery including rings!



### Note for disposal!

- Dispose of used drying agents in accordance with the regulations applicable in the country and site of use.



## Safety instructions for electrical works



### Deadly risk!

The operating voltage necessary for the system can have fatal consequences if live parts are touched!

- If a short circuit occurs there is the risk of sparking and fire.
- The system connection shall be dimensioned adequately to avoid overload.
- The operating voltage supply line must be equipped with a main switch with emergency switch-off function according to EN 60947-3 and 16 A back-up fuses by the customer.
- In the event of failure in the electrical power supply the system must be disconnected immediately.
- Active live parts of the electrical system must not be worked.



### Deadly risk!

Before commencing work with system parts, which are supplied with electrical power, switch system to zero potential on the main control switch and safeguard against unexpected resetting! Otherwise there is danger through electric voltage!

- Only use original fuses with stipulated current.
- The electrical system must be in sound condition and checked regularly. Defects, such as loose connections etc. shall be reported and remedied immediately.
- The switching cabinet as well as all connection and terminal boxes shall always be kept closed. Access for the purpose of inspection and maintenance of electrical equipment is only permitted to authorised personnel (see chapter "qualified personnel")
- The active parts of the electrical equipment must be protected against direct contact according to their voltage, frequency, usage category and place of operation by insulation, position, arrangement or permanent fittings.
- The electrical equipment must feature protection in direct contact according to its voltage, frequency, type of use and place of operation, so that in the case of a fault, there is protection available against dangerous touch voltage.

## Safety instructions for works on compressed air lines and pressure tanks



### Deadly risk!

The pressures necessary for the equipment can lead to injuries. During repair works on compressed air components, pressure lines and tanks to be opened shall be depressurised.

- The lines to be connected must be marked clearly and permanently, in order to rule out the dangers caused by a mix-up.



The air storage tank must be inspected at regular intervals. This inspection must take place according to customary regulations.

## Safety instructions for working with drying agents



### Deadly risk!

The pressures necessary for the equipment can lead to injuries. During repair works on compressed air components or drying agent containers, pressure lines to be opened shall be depressurised.



### Risk of injury!

- The drying agent has an absorbing effect and can lead to shrinkage after long contact with skin.
- In contact with water the drying agent generates heat, which can lead to mucosa and skin burns.



### Risk of injury!

Wear protective gloves when working with drying agents.



### Risk of injury!

Wear safety glasses when working with drying agents.

## Safety devices



Safety devices are put in place for the health and safety of employees employed on the equipment and protects the equipment against damage. The devices must be inspected regularly.

- The equipment may only be operated with functioning protective devices.
- The electrical components shall be provided with a cover plate. This must be mounted during operation.
- The safety devices must protect all moving and electrical parts and may not be handled or cancelled.



Before starting up equipment, ensure that the safety devices are mounted and functional.

The safety devices may only be removed

- After complete shutdown of equipment
- With safeguarding against warm restart of equipment

## Remaining dangers



The dangers emanating from the equipment, occur during work inside the metal cabinet and within the actual boundaries of the equipment, if the equipment has to be started up, e.g. for

- maintenance
- refitting
- fault diagnostics and remedy



In maintenance and refitting work, for which the equipment has to be started up, a second person should always be present to disconnect the equipment in an emergency situation. Always carry out work with greatest care and attention!

Watch out for the following dangers:

- Risk of injury by getting caught in the movement area of the compressor.
- Risk of injury caused by squashing and shutting in upper and lower limbs when assembling and disassembling the equipment.
- Risk of injury caused by squashing and shutting in upper and lower limbs when transporting equipment.

## Service conditions

### Temperatures

- Ambient temperature limit: +1 °C to + 40 °C  
Sound function is guaranteed in this temperature range.
- Temperatures outside of this range do not guarantee the functionality of the equipment.

### Ambient conditions

- Environmental media, especially chemically aggressive, can corrode seals, hoses, cables and plastics.
- Ambient media, especially chemically aggressive ones, might affect seals, hoses, cables and other plastic elements.

### Installation conditions

- The equipment should be installed in a dry, dust and frost-free room, while adhering to the general guidelines for work places.
- Furthermore, the equipment must be installed on a firm, load-bearing and level ground.

## Transportation



### Accident prevention!

The equipment may only be transported with sufficient means of transportation. It must be fixed securely during transportation. Avoid knocks to the equipment.

The equipment can be moved on a pallet to in-plant transport via an elevating platform truck or forklift truck. When moving the equipment mind the weight to prevent it from tipping or rolling.

- When moving the equipment keep the lifting height as low as possible.
- When moving the equipment pay attention that all electrical and pneumatic connections (also to the wiring harness and if required, reserve air storage tank) are disconnected.
- Observe the safety regulations for handling the elevating platform truck or forklift truck when moving equipment.

## Storage

### General information on storage

- If the equipment is not installed and started up immediately, it must be stored under appropriate storage conditions in a dry, dust and frost-free indoor area, protected from sunlight.
- The equipment should be wrapped in plastic or foil packaging.
- The storage time should not exceed one year.

## Functionality of pressurization system RT-UG 5000

The compressors draw in external air and compress this to approx. 7 bar. The air warmed up in this process is afterwards cooled down to approximately ambient temperature in a cooling coil which is vented by an additional fan. A cyclone water separator extracts dust and water particles from the air. Then the compressed air is channelled in the air dryer, alternatively by two drying agent containers, in which the air is dehumidified. In doing so, the air is only dried in one drying agent container, while at the same time in another drying agent container the existing drying agent is regenerated by a branch current of the already dried air. The humid regeneration air is disposed in an adequate drain.

The air dried in this way is stored in the air storage tank with a pressure between 3.5 and 5.0 bar. A pressure monitor ensures sufficient compressed air in the air storage tank, in which it switches the compressors on and off. The existing air pressure in the air storage tank can be read on the "high pressure" manometer.

A built-in air regulator reduces the stored compressed air from the air storage tank to the required cable pressure. This can be read on the "cable pressure" manometer.

This pressure-reduced air reaches the distribution device of the connected cable network via an shut-off valve and an injector. In order to guarantee proper operation the dried compressed air is constantly checked for its humidity content in the MFR unit. If the relative air humidity rises over approx. 4%, the compressor is switched off. A signal "F" is generated.

The pressure in the air storage tank is constantly monitored. If this rises to 7.0 bar, the pressure is blown off via a safety valve.

The equipment runs fully automatically after startup. Operational upsets are displayed on the mult functional relay (MFR) and the ACS unit at the instrument panel. In addition these fault signals are relayed to an external control centre.

The MFR distributes the drying and regenerating processes evenly to both drying containers by means of the solenoid valves. So none of them will be flooded, when only little amounts of air are produced.

The solenoid valves also allow for unpressurised compressor starts.

## Product description

### Product marking, connection and operation RT-UG 5000

- 1 **RT-UG 5000**
- 2 **Instrument panel**
- 3 **Product marking**  
The name plate is found on the bottom right of the front panel.
- 4 **Switch box**
- 5 **Connecting cable AC**
- 6 **Compressors** condense the air drawn in at approx. 7.0 bar
- 7 **Equipment air output to distribution panels**
- 8 **Lockable Side door**
- 9 **Condensate discharge hoses**



### Equipment's rear view

- 120 Pressure sensor „compressor pressure” [10.1] for the ACS device.** Measures the common output pressure of both compressors.
- 121 Safety valve compressor [10.1]** protects the compressor against excessive pressure. Blows off at approx. 7 bar.
- 122 Backpressure valve compressor** prevents compressors from back-flowing air.
- 123 Temperature sensor compressor for the ACS device.** Due to the position of the temperature sensor in the airstream, the real cylinder head temperature of the compressor is about 20 °C higher than the indication. The remote monitoring system considers this offset and the limits are set accordingly.

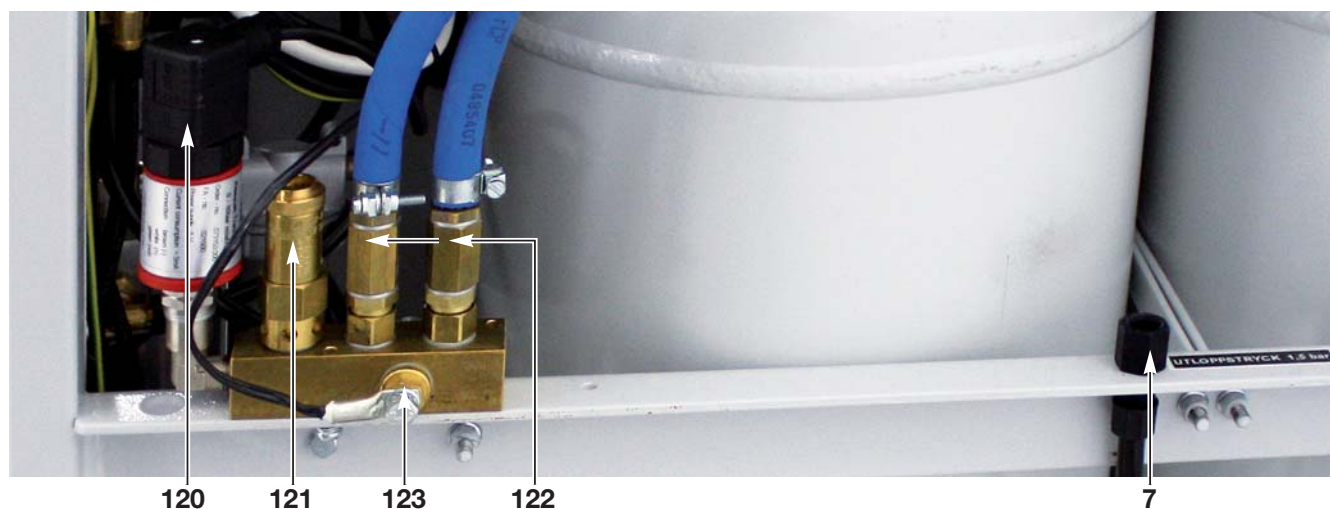

### Instrument panel

- 10 "High pressure" manometer [11.1]** displays the pressure in the air storage tank [9.1].
- 11 "Cable pressure" manometer [11.2]** displays the pressure of the air that flows to the outlet.
- 12 Green LED "Operating voltage"** glows when power is on.
- 13 Red LED "Fault"** glows when a system fault is pending.
- 14 Pressure reducer [12.1]**  
reduces the high-pressure to the designated output pressure. Preset.
- 15 Shut-off valve "Cable pressure" [13.1]**  
is used to open or close the pressurised air flow to the consumers.
- 16 ACS addressable compressor monitoring unit** captures 10 physical parameters of the pressurisation equipment and triggers an alarm when indicated: contact, system voltage, compressor runtime and operating hours, relative humidity and temperature of output air, ambient and compressor temperature, compressor pressure and amount of compressed air flow.

### 3 Product marking

The name plate is found on the bottom right of the front panel.

The code designations specified in squared brackets [ ] correspond to the pneumatic and electrical plans in the annex.

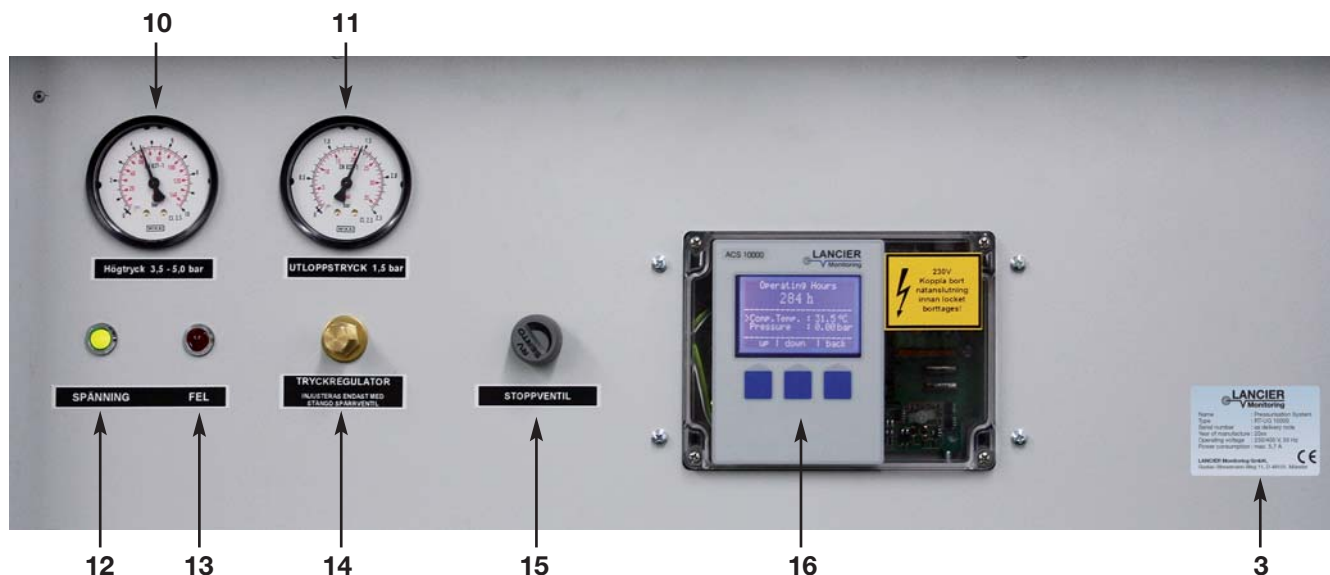



## Pressurised air supply, storage, drying and monitoring

- 17 2 air storage tanks [9.1] of 40 l each**, store the dried pressurised air.
- 18 Safety valve "high pressure" [10.4]** protects the air storage tank (17) [9.1] against excessive pressure.
- 19 Non-return valve [4.1]** prevents a reversed flow of pressurised air from the distribution device.
- 20 Safety valve "cable pressure" [10.5]** protects the pressurised air consumer load against excessive pressure.
- 21 Fan [E1]** vents the compressor exhaust air cooler area.
- 22 Compressor hose [3.1]** leads the compressor exhaust air to the cooler/dryer system.
- 23 Cooler [3.1]** for the compressor exhaust air.
- 24 Air dryer [5.1]** dries the pressurised air alternatively in one of the two containers, while the drying agent is regenerated in the other container.
- 25 Solenoid valves for air dryer [left:Y1 and Y1.1, right Y2 and Y2.1]** control the air flow alternatively by one of the two drying agent containers and lead the regeneration air flow from the passive drying agent container outside (to condensate surge tank).
- 26 Cyclone water separator** dewateres the cooled compressed air by the cyclone process.
- 27 Solenoid valve for the cyclone water separator** controls the water flow to the drain.
- 28 Micro filter [1.5]** protects the control and measurement devices from contaminations.
- 29 Pressure limiting valve [8.1]** opens when the air flow has reached a pressure of 5.5 bar after leaving the air dryer (24) [5.1].
- 30 Double non-return valve [6.1]** routes the dried pressurised air in the active drying agent container to the air storage tank (17) [9.1] and returns a part of the air flow for regeneration of the drying agent into the passive drying agent container.
- 31 Pressure monitor [F6]** monitors the pressure in the air storage tank (17) [9.1] and switches the compressors on and off once the upper and lower pressure value is reached.
- 32 Humidity sensor for MFR** monitors the relative humidity of the output air. When reaching the upper limit, the MFR activates fault „F“ and shuts the system down.
- 38 Pressure switch "high pressure" [B1]** activates a dry contact when the pressure in the air storage tank drops below 1.0 bar.
- 125 T-piece with sealing plug**

The code designations specified in squared brackets [ ] correspond to the pneumatic and electrical plans in the annex.

Interior



Back of instrument panel

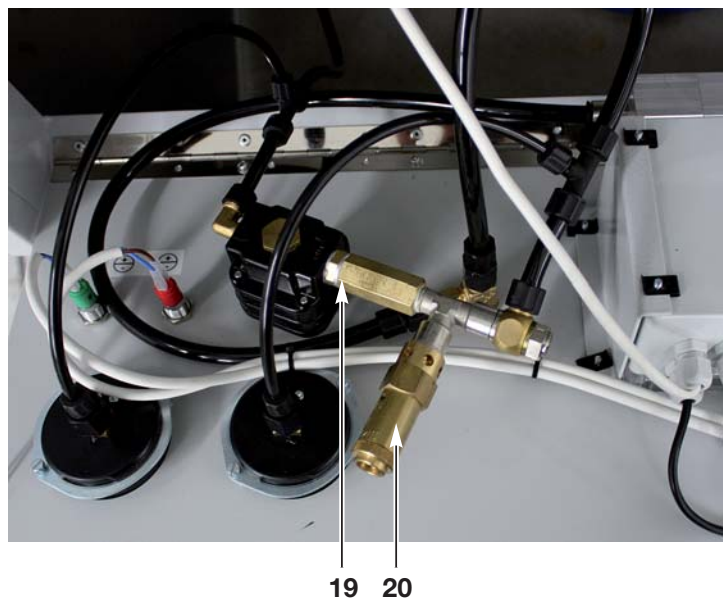





## Multifunctional Relay MFR

The MFR controls and monitors the pressurisation equipment. It is placed in the switch box.

- 47 Signal-LED „DC“
- 48 Signal-LED „F“
- 51 Signal-LED „N“
- 52 Signal-LED „AC“
- 53 Signal-LED „Remote“
- 54 Signal-LED „F-On“
- 55 Signal-LED „T-Runtime“
- 59 Signal-LED „Y1 state“
- 60 Signal-LED „Y2 state“
- 61 Signal-LED „Comp OK“
- 62 Signal-LED „State Comp in“
- 63 Signal output-LED „W“
- 64 Signal output-LED „A“
- 65 Signal output-LED „N“ (not installed)
- 67 Button „F-Off“
- 69 Button „Reset maintenance“ [S10]
- 70 Button „Test“ W Signal, A Signal [S9]
- A Fuse „AC“
- B Fuse „DC“
- KY1 Relay with labeling acc. to wiring diagram

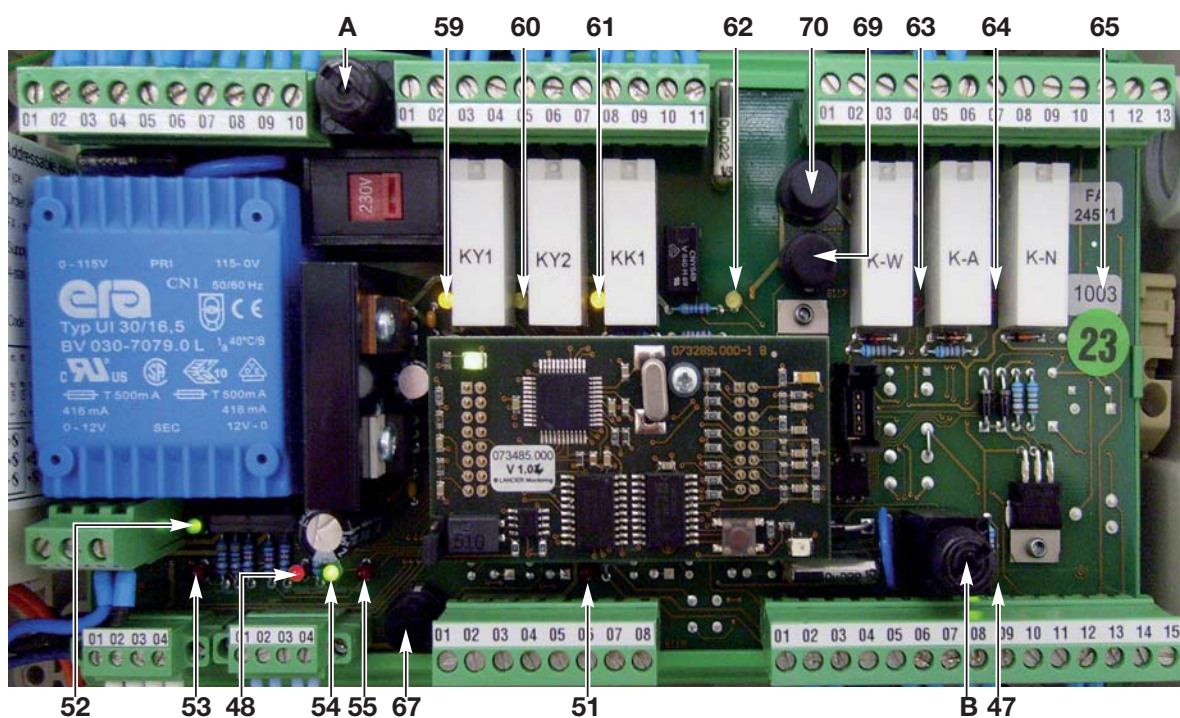

## Electrics

### 33 2 Motor protective switches [Q4] and [Q5]

to manually switch the compressors on and off, features a built-in protective relay to protect the motor from excessive current consumption.

### 34 Auxiliary switches of [Q4] and [Q5]

provide the CDtA sensors with the state condition of the motor protective switches (33) [Q4] and [Q5] for remote monitoring.

### 35 Motor contactors / switches [K1] and [K2]

switch the compressors (18) [2.1] and [2.1] on and off after the switching of the pressure monitor (31) [F6].

### 36 Multifunctional relay MFR

controls all workflows of the pressurisation equipment, among others:

- redirects the solenoid valves (25) [Y1 and Y1.1 , Y2 and Y2.1] to change the drying agent container in the clock pulse.
- switches off the compressors via the motor contactors / switches (35) [K1] and [K2] and activates the signal "F" when the humidity content of the dried air is inadmissibly high.
- activates the output common signal "A" (fault) in potential free form, when the faults "F" is pending, or if the systems AC power broke down. The individual signals of the output common signal are dependent on equipment.

### 37 2 Sensors CDtA

Each CDtA sensor monitors one motor protective switch [Q4] and [Q5] and sends an alarm via the Tx-bus to the monitoring system, if one of the switches turns off.

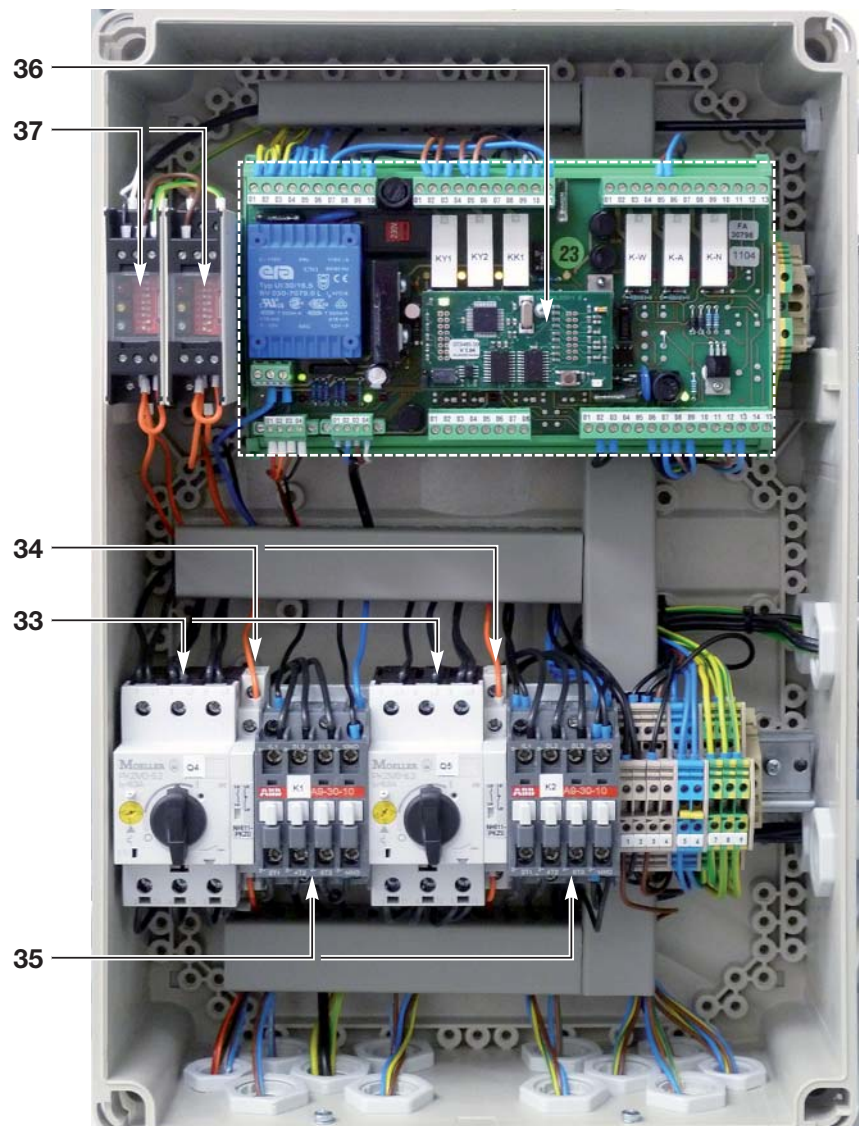

## Mounting

### Setting up the system RT-UG 5000

The pressurisation equipment RT-UG 5000 is designed to be located at floor level. The floor must be constructed for exposure to dynamic stresses and strains. LANCIER Monitoring assumes no liability whatsoever for wall mounting.

The place of mounting should be dry and swept clean.

#### Minimum distance to adjacent walls and equipment = 500 mm

The pressurisation equipment RT-UG 5000 must be fixed to the ground by screws at the 4 bottom fixing holes (38) placed at the corners inside of the equipment.

#### Connect the condensate discharge hose

- Guide the condensate discharge hose (9) from the back of the equipment to the next adequate drain, insert and fix it.
- The drain should have venting holes!

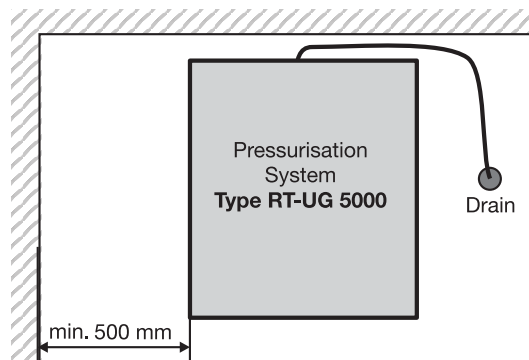

38

## Mounting of the switch box

The switch box (4) is electrically fully connected. For transportation purposes it is tilted and fixed horizontally.

1. Unpack the switch box (4) and remove its lid (40). To do so open the 4 screws at the blue corners with a slotted screwdriver.
2. Erect the switch box (4) and fix it at the 4 fixing points (41) with the delivered screws. The screws for fixing the back are inserted through the lid fixing screw holes (42).

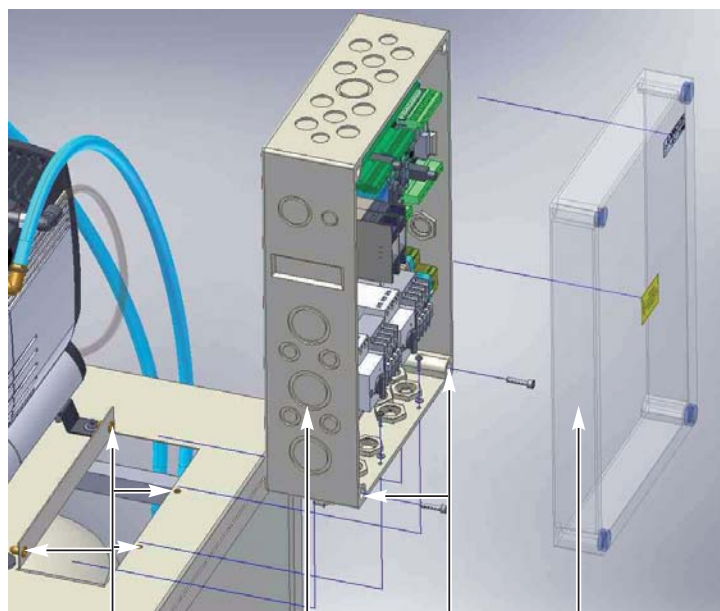

41

4

42

40



4



## Mounting of the compressors



### Health hazard!

The compressors (6) weigh about 34 kg each.

Apply for correct lifting techniques and wear safety shoes!

- Correct lifting stresses the spinal discs equally.
- Wrong lifting stresses the spinal discs one-sided and might lead to health hazard.

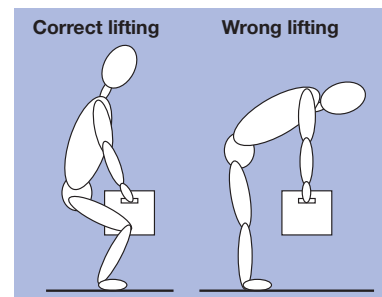

### Mounting the compressors

1. Place washers (72) above the 4 right-hand side inserted nuts on top of the pressurisation equipment. Fit the mounting brackets (75) of one of the compressors (6) on top of the washers (72).  
The air-outlet (78) should look to the right.
2. Place the twisted air filter retainer (71) with the premounted airfilter at the left front fixing point and fix it with a screw.
3. Fix the 3 remaining screws (77) with a screwdriver.
4. Mount the second compressor (6) in the same way at 4 left-hand side inserted nuts.

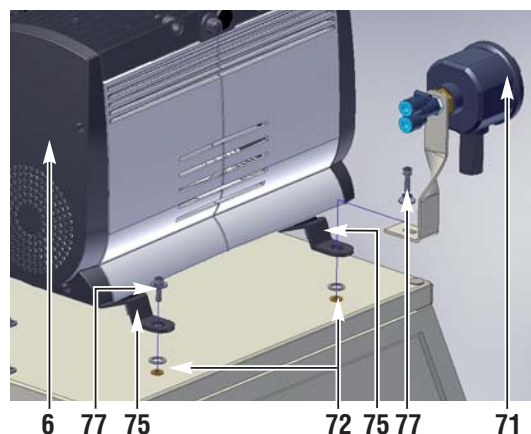

### Connecting the compressors

5. Connect both chambers of each compressor with the air intake filter (80) as shown (red marked hoses):  

 slip the delivered transparent air hose (81) into the quick connect couplings (82) with the blue ring at the filter and the compressor as far as it will go. The couplings are self-locking.

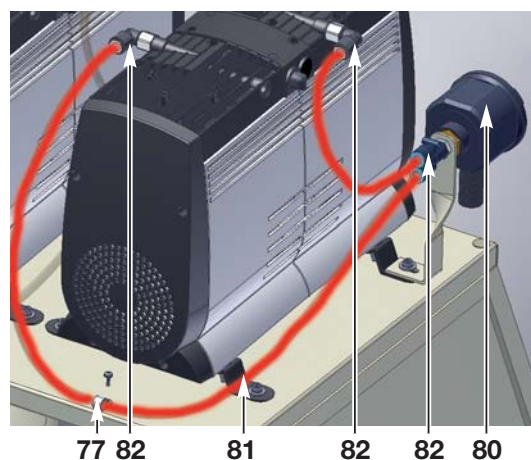
Fix the longer air hose with a clamp (77) at the back of the top of the pressurisation equipment.



Completed compressor mounting rear view



front view.

6. Connect both compressor hoses (22) to one of the 2 compressors air-outlets (78) each.  
The hoses (22) should be curved slightly upwards and shall not touch any parts of the compressors or the the pressurisation equipment.  
Fix the swivel nut (79) with a spanner.

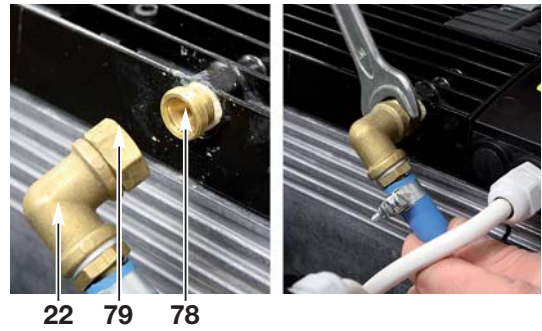

**⚠ Risk of damage!**  
The compressor hoses should touch parts of the compressors or the the pressurisation equipment!  
Risk of damage because of fraying!  
Risk of damage because of hot surfaces!

7. Connect both compressor connection cables (83) to one of the 2 power plugs each (84) at the back of the switch box (4).  
Connect **left compressor** to **plug „Kompressor 1”**  
Connect **right compressor** to **plug „Kompressor 2”**

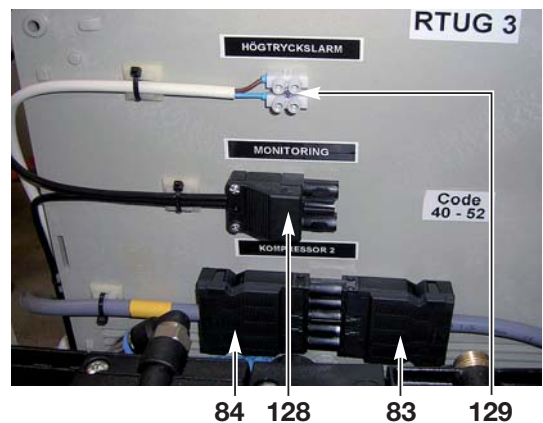

**⚠ Risk of damage!**  
The compressor connection cables should be installed thoroughly to avoid damage because of fraying!

## Connecting the monitoring system

The monitoring system is connected by a cable with pre-assembled plug to connector (128) at the back of the switch box (4).

## Connecting the signal output „High pressure alarm”

The dry contact output „High pressure alarm” of the high pressure switch B1 can be tapped at the clamp „Hogtryckalarm” (129) at the back of the switch box (4).

## Electrical connection



**Deadly risk!**

**Electrical connection must only be made by electrical specialists!**

**After connecting electricity: Take caution with live components!**

### Operating voltage AC

- Before connection to the mains supply mind that the power supply voltage complies with the operating voltage of the compressors (6) (see compressors name plate!)
- The operating voltage supply line must be secured with **16 A back-up fuses and a main switch with emergency stop function according to EN 60947-3!**
- Check fuse setting of both motor protective switches (33) (see page 32)!
- Connect connecting cable AC (5) as follows:

#### 5-core with 3-phases

- green/yellow to PE (protective earth)
- blue marked 4 to N (neutral)
- black 1 to L1 (Phase)
- black 2 to L2 (Phase)
- black 3 to L3 (Phase)

(see circuit and wiring diagram pages 52 and following)

- Check rotating direction of the compressors (6) e. g. by inserting a flexible wire cautiously into its ventilation grid. The left compressor should run clockwise, the right one should run anti-clockwise as indicated on the compressor's ventilation grid.
- If the rotating direction is not as indicated, exchange the the two cores black 1 and black 2 of the connecting cable at the terminal. Check rotating direction of the compressors (6) again.



## Operation of the Compressor Monitoring Unit ACS

The compressor monitoring unit ACS (16) captures 10 physical parameters of the pressurisation equipment and triggers an alarm when indicated: contact, system voltage, compressor runtime and operating hours, relative humidity and temperature of output air, ambient and compressor temperature, compressor pressure and amount of compressed air flow are monitored. The measured values can be indicated at the internal LC-display.

The ACS can be integrated as an addressable sensor into a connected monitoring system and trigger automatic alarms when indicated.

It also can display all values and alarm conditions of the MFR (36).

Some parameters of the pressurisation equipment can be adjusted via the ACS. To do so it is necessary to log-in into a special protected service mode (see page 26). Specially skilled personal only is authorized to execute the adjustments.

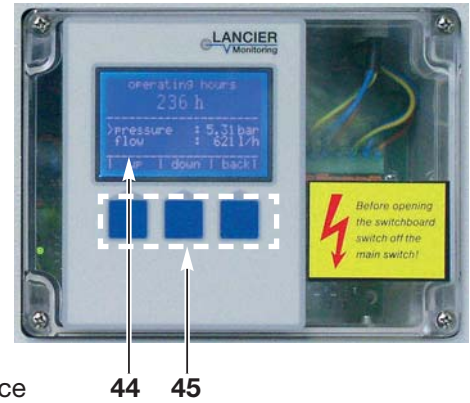

### Start the ACS

The ACS starts automatically when the pressurisation equipment is switched on. The last display contents that has been shown longer than 10 seconds is automatically stored and will be shown after the re-start. At first start it will display **D1** shown on the opposite page.

### Operating the ACS

The ACS operation is menu-driven. Menu items are selected by soft keys (45). The assigned functions of the soft keys are indicated in the display (44) directly above the respective key (45).

The active menu item is marked „>“.

The marker „>“ can be moved „up“ and „down“ by the adequate keys.

Pressing the soft key „select“ chooses the menu item.

To return to a higher menu level choose menu item „back“ or press soft key „back“.

All menus and submenus are shown at the diagram on the opposite page.

### Read ACS values

Menu selection:

**Menu D1** >Disp. Device : ACS press soft key „select“

**Menu D2.1** >ACS - Current Values press key „select“

The display shown right hand **D3.1** appears:

Large reading = Top Value (46) (refer to chapter „set top value“), here „Operating Hour“ = total operating hours of the pressurisation equipment,

2 smaller readings below: by scrolling with the soft keys (45) „up“ and „down“ the following readings appear consecutively in the display:

- |               |                        |  |
|---------------|------------------------|--|
| - Contact     | : <i>open or close</i> | state of a floating contact, open or closed (e. g. door contact, water level indicator etc.)   |
| - Power       | : <i>on or off</i>     | operating voltage on or off  |
| - Compressor  | : <i>on or off</i>     | compressors on or off  |
| - Runtime     | : <i>value sec</i>     | last compressor runtime in seconds   |
| - Operating   | : <i>value h</i>       | total operating hours of the pressurisation equipment  |
| - Humidity    | : <i>value %rh</i>     | rel. humidity of the output air in %   |
| - Air Temp.   | : <i>value °C</i>      | temperature of the output air in °C  |
| - Ext. Temp.  | : <i>value °C</i>      | ambient temperature in °C (option „external temperature sensor“ must be installed)   |
| - Comp.Temp.: | <i>value °C</i>        | compressor temperature in °C (due to the position of the temperature sensor in the airstream, the real compressor temperature is about 20 °C higher than the indication) |
| - Pressure    | : <i>value bar</i>     | pressure of the output air in bar (option „external pressure sensor“ must be installed)  |
| - Flow        | : <i>value l/h</i>     | amount of the output air in liters/hour (at option ACS-F only)   |

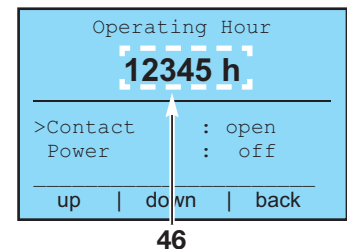



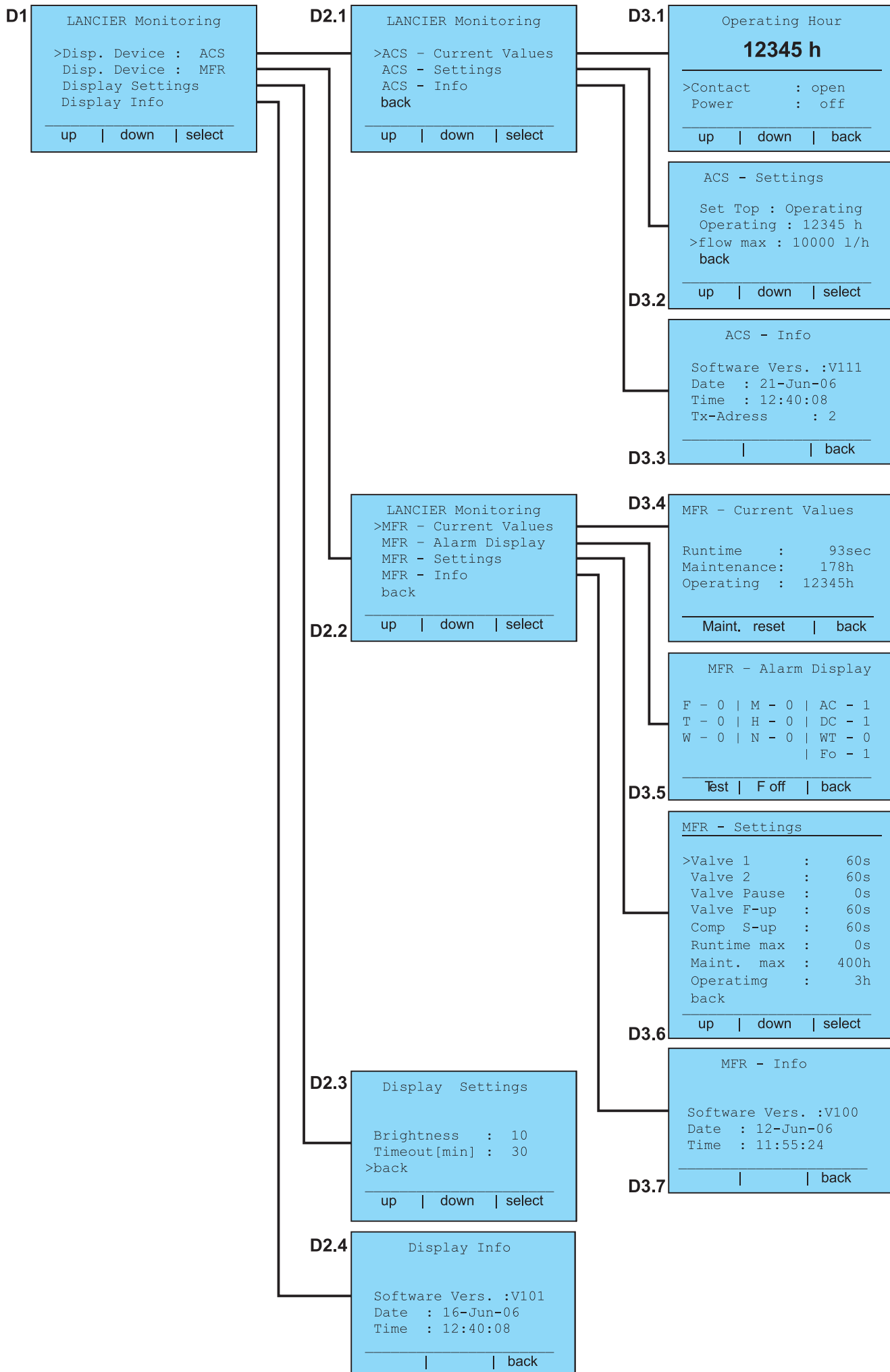

## Read ACS-Info

Menu selection:

**Menu D1** >Disp. Device : ACS press soft key „select“  
**Menu D2.1** >ACS - Info press soft key „select“

```
ACS - Info
Software Vers. :V111
Date : 21-Jun-06
Time : 12:40:08
Tx-Adress : 2
| | back
```

Display **D3.3** „ACS - Info“ appears:

Version, date and time of the ACS software release and the first Tx bus address of the ACS are displayed. The ACS uses 10 addresses on the Tx bus (the one indicated on the display and the next following 9). So the LANCIER monitoring system can allocate all readings explicitly.

## Read MFR values

Menu selection:

**Menu D1** >Disp. Device : MFR press soft key „select“  
**Menu D2.2** >MFR - Current Values press soft key „select“

```
MFR - Current Values
Runtime : 93sec
Maintenance: 178h
Operating : 12345h
| | back
```

Display **D3.4** „MFR - current values“ appears:

- Runtime : *value* sec last compressor runtime in seconds  
 - Maintenance: *value* h remaining runtime period until maintenance must be carried out in hours  
 - Operating : *value* h total operating hours of the pressurisation equipment

## Reset maintenance counter

The counter for the remaining maintenance time of the MFR can be reset by the ACS. Go to display **D3.4** as described in the previous chapter „Read MFR values“.

Press down both soft keys „Maint.“ and „reset“ for 5 seconds at the same time.

The value „Maintenance“ will rise to „400 h“. **This action is irreversible!**

## Poll MFR alarm conditions

Menu selection:

**Menu D1** >Disp. Device : MFR press soft key „select“  
**Menu D2.2** >MFR - Alarm Display press soft key „select“

```
MFR - Alarm Display
F - 0 | M - 0 | AC - 1
T - 0 | H - 0 | DC - 1
W - 0 | N - 0 | WT - 0
| Fo - 1
| | back
```

Display **D3.5** „MFR - alarm display“ appears:

Alarms	Signalisation
F = humidity	AC = operating voltage
T = compressor runtime	DC = signal voltage (option)
W = maintenance	WT = door contact open (option)
M = motor protection	Fo = humidity monitoring

0 = no alarm                      0 = off            1 = on  
 1 = alarm

## Test of MFR alarmdisplay

Pressing of the soft key „Test“ in Display **D3.5** activates all alarm relays. All alarm values of the ACS (**16**) turn to „1“.

The LEDs „F“ (**48**), „N“ (**51**) and „T-Runtime“ (**55**) as well as the signal output LEDs „W“, „A“ and „N“ (**63-65**) illuminate on the MFR (**36**).

The responding alarms must emerge in the remote control station.

## Deactivating humidity monitoring of the MFR

Pressing of the soft key „F off“ in display **D3.5** deactivates the humidity monitoring of the MFR (see chapter „leave the equipment to run dry“, page 31). The indication of „Fo“ in the ACS (**16**) turns to „0“.

The LED „F-on“ (**54**) on the MFR (**36**) goes out.

To reactivate the humidity monitoring immediately press the soft key „F off“ for about 5 seconds. If the reactivation of the humidity monitoring is not executed manually, it will activate itself after approximately 2 operating hours.

## Read MFR settings

Menu selection:

**Menu D1** >Disp. Ddevice : MFR press soft key „select“

**Menu D2.2** >MFR - Settings press soft key „select“

Display **D3.6** „MFR - Settings“ appears:

By scrolling with the soft keys (45) „up“ and „down“ the following fixed values appear consecutively in the display:

MFR - Settings	
>Valve 1	: 60s
Valve 2	: 60s
Valve Pause	: 0s
Valve F_up	: 60s
up   down   select	

Display	Parameter	Value range
- Valve 1	: <i>value</i> s runtime of solenoid valve Y1 in seconds	0 .. 250 sec
- Valve 2	: <i>value</i> s runtime of solenoid valve Y2 in seconds	0 .. 250 sec
- Valve Pause	: <i>value</i> s runtime rest of the solenoid valves (- = overlap, + = rest in seconds)	-125 .. +125 sec
- Valve F-up	: <i>value</i> s solenoid valve stopping time after switch-off of the compressors in seconds	0 .. 250 sec
- Comp S-up	: <i>value</i> s opening time (+) resp. closing time (-) of both valves in seconds, to prevent the starting of the compressors against counter pressure	-125 .. +125 sec
- Runtime max	: <i>value</i> s maximum compressor runtime in seconds	0 .. 10.000 sec
- Maint. max	: <i>value</i> h maintenance interval in hours	0 .. 10.000 h
- Operating	: <i>value</i> h total operating hours of the pressurisation equipment (set-up see service mode, page 26)	0 .. 99.999 h

## Read MFR info

Menu selection:

**Menu D1** >Disp. Device : MFR press soft key „select“

**Menu D2.2** >MFR - Info press soft key „select“

Display **D3.7** „MFR - Info“ appears:

Version, date and time of the MFR software release are displayed.

MFR - Info	
Software Vers. :	V100
Date :	12-Jun-06
Time :	11:55:24
up   back	

## Display settings

Menu selection:

**Menu D1** >Display Settings press soft key „select“

Display **D2.3** „Display Settings“ appears:

Choose the value to edit by scrolling with the soft keys (45) „up“ and „down“:  
*Brightness* = brightness of the display (value 0 - 15)

*Timeout (min)* = time period in minutes after which the display goes out if not used (value 0 - 250 min.).

Pressing the soft key „select“ chooses the value.

Pressing the soft keys (45) „up“ and „down“ raise or lower the value.

Pressing the soft key „set“ stores the set value.

Display Settings	
Brightness	: 10
Timeout [min]	: 30
>back	
up   down   select	

## Read display info

Menu selection:

**Menu D1** >Display Info press soft key „select“

Display **D2.4** „Display Info“ appears:

Version, date and time of the display software release are displayed.

Display Info	
Software Vers. :	V101
Date :	16-Jun-06
Time :	12:40:08
up   back	

## Service mode

System parameters of the MFR and the operating time counter of the ACS can be edited in the service mode.



### WARNING!

These tasks must be accomplished by qualified personnel only.  
The functionality of the pressurisation equipment may be damaged.

Menu selection:

**Menu D1** >Display Settings press soft key „select“

Display **D2.3** „Display Settings“ appears:

Pressing both soft keys (45) „up“ and „down“ at the same time activates the service mode for 10 minutes.

The text „Service : active“ appears on the display above the line „Brightness“.

```

Display Settings

Brightness : 10
Timeout[min] : 30
>back
-----
up | down | select
  
```

## ACS settings

Menu selection:

**Menu D2.3** >back press soft key „select“

**Menu D1** >Disp. Device : ACS press soft key „select“

**Menu D2.1** >ACS - Settings press soft key „select“

Display **D3.2** „ACS - Settings“ appears.

The amount of total operating hours can be set here (e. g. after substitution of the ACS or a compressor).

Use soft keys (45) „up“ and „down“ to choose the value „Operating“.

Press soft key „select“.

Pressing the soft keys (45) „up“ and „down“ raise or lower the value.

Pressing the keys for a longer time increases the speed of alteration of the values of „runtime“, „maintenance“ and „operating hours“.

Pressing the soft key „set“ stores the set value.

```

ACS - Settings

>Set Top : Operating
Operating : 12345 h
flow max : 10000 l/h
back
-----
up | down | select
  
```

## MFR settings

Menu selection:

**Menu D2.3** >back press soft key „select“

**Menu D1** >Disp. Device : MFR press soft key „select“

**Menu D2.2** >MFR - Settings press soft key „select“

Display **D3.6** „MFR - Settings“ appears.

All values of the MFR set-up can be changed here (e. g. after substitution of system components).

Use soft keys (45) „up“ and „down“ to choose the value to change.

Press soft key „select“.

Pressing the soft keys (45) „up“ and „down“ raise or lower the value.

Pressing the keys for a longer time increases the speed of alteration of the values of „runtime“, „maintenance“ and „operating hours“.

If no runtime monitoring is required, set parameter „Runtime max.“ to „0s“

Pressing the soft key „set“ stores the set value.

```

MFR - Settings

>Valve 1 : 60s
Valve 2 : 60s
Valve Pause : 0s
Valve F_up : 60s
-----
up | down | select
  
```

**ACS set „top value”**

Menu selection:

**Menu D1** >Disp. Device : ACS press soft key „select“**Menu D2.1** >ACS - Settings press soft key „select“Display **D3.2** „ACS - Settings“ appears.

Choose value „Set Top“ using the soft keys (45) „up“ and „down“ .

Press soft key „select“.

By scrolling with the soft keys (45) „up“ and „down“ all values from the chapter „read ACS values“ appear consecutively in the display.

Pressing the soft key „set“ selects the chosen value as „top value“.

```

ACS - Settings
>Set Top : Operating
Operating : 12345 h
flow max : 10000 l/h
back
-----
up | down | select

```

**Set up Air Flow Value**

Menu selection:

**Menu D1** >Disp. Device : ACS press soft key „select“**Menu D2.1** >ACS - Settings press soft key „select“

The air flow value must be set accordingly to the mounted flow module. Factory setting is already appropriate.

Display **D3.2** „ACS - Settings“ appears.

Choose value „flow max“ using the soft keys (45) „up“ and „down“ .

Press soft key „select“.

Use softkeys (45) „up“ and „down“ to change between 5000 and 10000 l/h

Press softkey „set“ to store the selected value.

```

ACS - Settings

Set Top : Operating
Operating : 12345 h
>flow max : 10000 l/h
back
-----
up | down | select

```

**Service mode is closed automatically after 10 minutes.**

## Operation of multifunctional relay MFR

The MFR (36) controls and monitors the vital functions of the pressurisation equipment. Several alarm conditions are forwarded to external signal outputs for remote alarming purposes.



### Deadly risk!

**Electro specialists only are allowed to operate the buttons of the MFR.  
Other users must use the ACS to operate the system.**

## Meaning of the LEDs

### Normal operation

- 47 Signal LED „DC“** illuminates, when signal voltage is on: mainswitch signal voltage DC (6) is switched on, fuse „B“ is intact.
- 52 Signal LED „AC“** illuminates, when supply voltage is on: motor protective switch (5) is switched on, fuse „A“ is intact.
- 54 Signal LED „F-on“** illuminates, when humidity monitoring is on.  
Turns off, when humidity monitoring is bypassed (e. g. running dry of the system) by pressing the button „F-off“ (67).
- 59 Signal-LED „Y1 state“** illuminates, when air dryer 1 is active (relay KY1 and solenoid Y1 are activated).
- 60 Signal-LED „Y2 state“** illuminates, when air dryer 2 is active (relay KY2 and solenoid Y2 are activated).
- 61 Signal-LED „Comp OK“** illuminates, when the compressors are ready for use and the system is fault-free.
- 62 Signal-LED „State Comp in“** flashes as soon as the compressors are running.
- 53 Signal-LED „Remote“** flashes during data exchange between MFR (73) and ACS (16).

### Alarms

- 48 Signal-LED „F“** illuminates, when the maximal admissible amount of humidity in the output air is exceeded.
- 51 Signal-LED „N“** illuminates when the minimum cable pressure is underrun (option not installed).
- 55 Signal-LED „T-Runtime“** illuminates, when the compressors were switched off by the MFR because of run time overstepping (option not installed).
- 63 Signal output-LED „W“** illuminates, when the preset maintenance interval (normally 400 hrs.) is overrun and the signal relay K-W is activated = external signal (option not installed).
- 64 Signal output-LED „A“** illuminates, when a system signal is pending (generated by „F“-fault respectively breakdown of supply voltage) and the signal relay K-A is activated = external alarm is activated.
- 65 Signal output-LED „N“** illuminates, when cable pressure fell 2.0 bar below preset limit value and the signal relay K-N is activated = external alarm is activated (option not installed).  
**Signal output-LED „N“** illuminates also, when the admissible cable pressure is exceeded (if equipped with optional pressure switch „cable pressure too high“ only (30)) (option not installed).

### Buttons

- 67 Button „F-Off“** [S11] switches off humidity monitoring, e.g. to run dry the system (see page 31).  
- Signal-LED „F-on“ (54) turns off.  
Pressing the button for 5 seconds reactivates the humidity monitoring.  
- Signal-LED „F-on“ (54) illuminates again.
- 69 Button „Reset maintenance“** [S10] must be pressed down for 5 seconds to reset the operating hour meter to the default value of 400 hours.  
**This process is irreversible!**  
- Signal-LED „W“ (63) turns off, if it has been already activated.
- 70 Button „Test“ A Signal** [S9] may be pressed to check an optionally connected external signalisation.  
- Relais „K-W“ activates and Relais „K-A“ deactivates.  
- Signal LED „A“ (64) illuminates.  
- Alarm „A“ must occur in the remote control center if a signal line is connected.

### Fuses

- A Fuse „AC“** safeguards the AC circuit (supply voltage).  
Type: 0,315 A, medium time lag
- B Fuse „DC“** safeguards the DC circuit (signal voltage).  
Type: 2 A, medium time lag

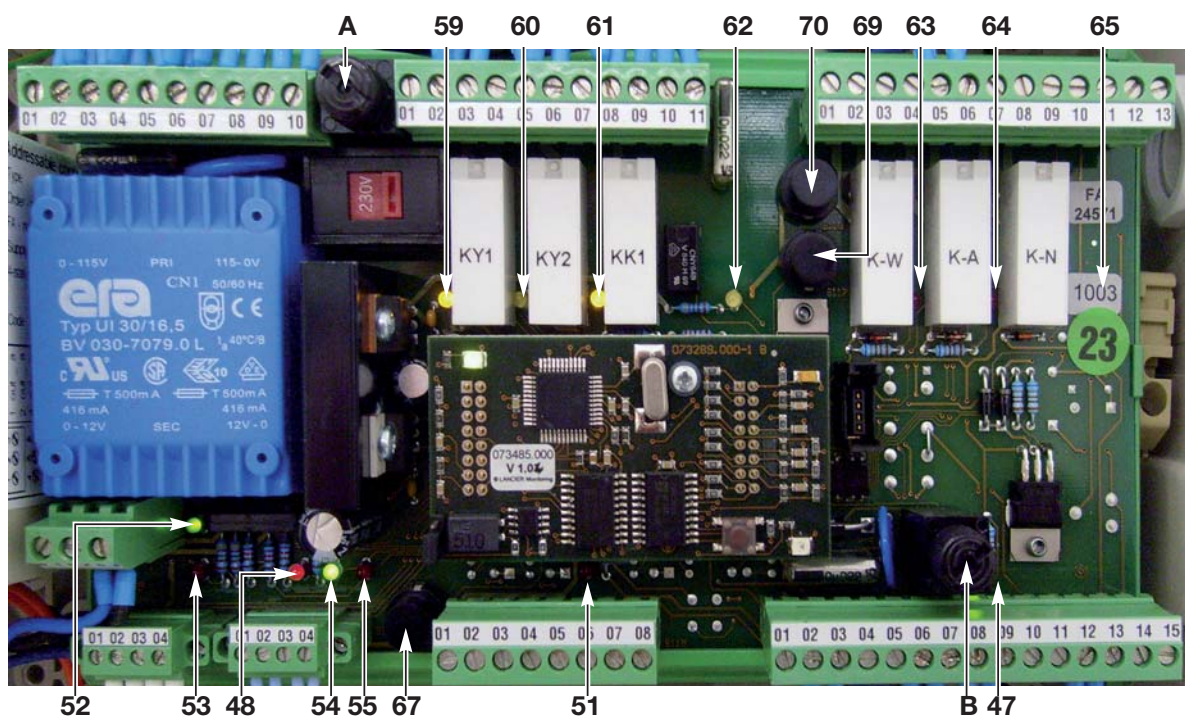



## Start-up



**Deadly risk!**  
Do not operate the equipment with damp hands!  
Take caution with live components!



**Risk of injury!**  
Take caution with heated components!

### Before start-up

The connecting hose is not yet connected to the consumer load.

- Close shut-off valve "cable pressure" (15) at the instrument panel (14).

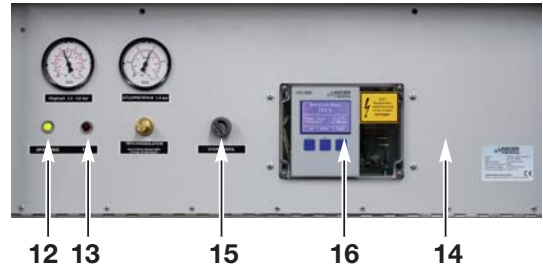

Connect and activate main power.

### Check indications of MFR (36)

- Green Signal-LED „DC“ (47) illuminates.

### Check indications at the instrument panel (14)

- The green Signal-LED „Operating voltage“ (12) illuminates.
- The red Signal-LED „Fault“ (13) is off.

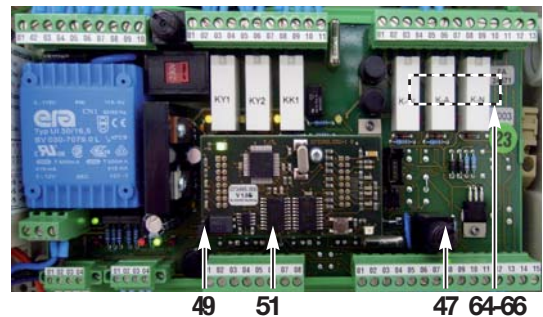

## Set the equipment into operation / charge equipment

Main power is connected and activated.

Turn both motor protective switches (33) to "I".

- The compressors start.

### The MFR (36) indicates at the same time

- The yellow Signal-LED „State Comp in“ (62) flashes.
- The yellow Signal-LED „Comp OK“ (61) illuminates.
- The green Signal-LED „AC“ (52) illuminates.
- The yellow Signal-LEDs (59-62) illuminate, after a short time either LED „Y1 state“ (59) or LED „Y2 state“ (60) turns off (cylinder-head ventilation of the compressors is completed).
- The green Signal-LED „F-on“ (54) illuminates (humidity monitoring is active).

### Check indications at the instrument panel (14)

- The green Signal-LED „Operating voltage“ (12) illuminates.
- The red Signal-LED „Fault“ (13) turns off.

### Observe "high pressure" manometer (10)

- at 5.0 bar the compressors switch off.
- The yellow Signal-LED „State Comp in“ (62) in the MFR turns off.



### Troubleshooting!

If the compressors do not run, this may be due to an electrical fault or hose lines and air dryer becoming damp after long idle period.

- The green LED „F-on“ (54) illuminates in the MFR (36) = humidity monitoring is active.
- The red Signal-LED „F“ (48) **flashes** in the MFR = either the electrical connection to the humidity sensor or the humidity sensor (32) itself is broken.  
In this case check the connection-line or change the humidity sensor (32) (see page 44 „Causes and remedy of faults”).
- **or**
- The red Signal-LED „F“ (48) **illuminates** permanently in the MFR = pressurised air humidity is unadmissibly high.

In this case leave the equipment to "run dry":



### Deadly risk!

Electro specialists only are allowed to operate the buttons of the MFR.  
Other users have to use the ACS device (16).

- Open safety valve "high pressure" (18).
- Press button „F-Off“ (67) on the MFR (36) or ACS (16).
- The compressors start.
- The green Signal-LED „F-on“ (54) in the MFR is turned off = no humidity monitoring.
- The red Signal-LED „F“ (48) illuminates in the MFR = pressurised air humidity is unadmissibly high.



18

### After a while

- The red Signal-LED „F“ (48) on the MFR turns off = the pressurised air is dry.
- The green Signal-LED „F-on“ (54) on the MFR is still turned off = no humidity monitoring.



### Warning!

Pressing the button „F-off“ overrides the humidity monitoring.

The button must be used only, if a fault occurred, the „high pressure“ safety valve (18) is open and the shut-off valve "cable pressure" (15) is shut.

Humidity monitoring must be reactivated immediately after trouble-shooting, to assure proper function of the pressurisation equipment.

In order to get immediate humidity monitoring, the "F-off" operation must be overridden:

- Press button „F-Off“ (67) of the MFR or of the ACS for approx. 5 seconds.
- The green LEDs „F-On“ (54) on the MFR illuminate again.
- Close safety valve "high pressure" (18).
- Then carry out function testing.

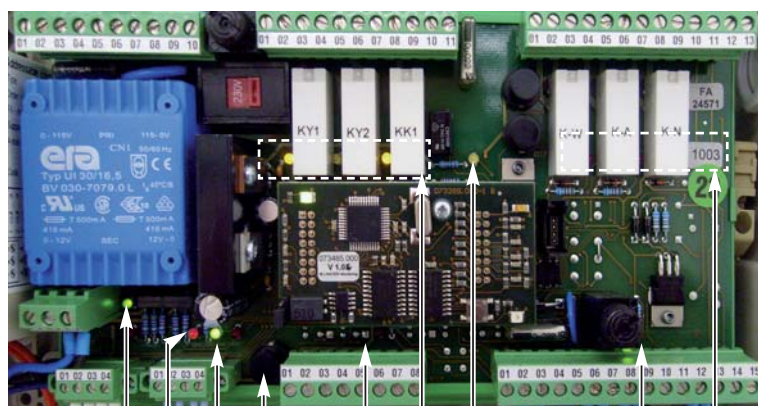

MFR

52

48

54

67

51

59-61

62

47

63-65

The humidity monitoring activates itself automatically after approx. 2 operating hours of the compressor, if the „F-off“ operation is not determined manually.

Switching the motor protective switch (33) off and on again, terminates the „F-off“ operation also. This procedure resets the MFR by breaking its power supply.

## Function testing / setting of components

After start-up always test the equipment for correct function!

In the case of function error, in spite of correcting the setting, see page 44 "Causes and remedying of faults".  
For function testing or setting, in the case of some components the cabinet door (8) must be open and the lid (39) of the switch box (4) unscrewed.

The inspections or settings shall partly be carried out when the equipment is on.



**Deadly risk!**

**Do not operate the equipment with damp hands!  
Take caution with live components!**



**Risk of injury!**

**Take caution with heated components!**

### Check and set reference value motor protective switch back-up fuse

#### Check setting

Reference value of setting screw (85):

**RT-UG 5000:** 400 V, 50 Hz: approx. 5,3

#### Change setting



**Deadly risk!**

**Switch off operating voltage,  
Unscrew or disconnect back-up fuse!**

- Then with a small screw driver turn the setting screw (85) approximately to the setting indicated above.
- Switch on operating voltage again.



85



**Hint!**

**The motor protective switch must be set approx. 0.3 A above power consumption of the compressor motor (6) (see compressor name plate).**

## Check and set the pressure switch "high pressure"



**Deadly risk!**

**Working on open, live equipment!**

- Do not operate the equipment with damp hands!
- Caution: live components!!

### Setpoint value switching pressure

Pressure switch "high pressure" (38)

=  $1.0 \pm 0.1$  bar

- Close shut-off valve (15) at the instrument panel.
- Open safety valve "high pressure" (18) at the air storage tank (17) and observe manometer "high pressure" (10):
  - the pressure drops.
  - on reaching the setpoint value the signal contact closes.
- Close safety valve "high pressure" (18).

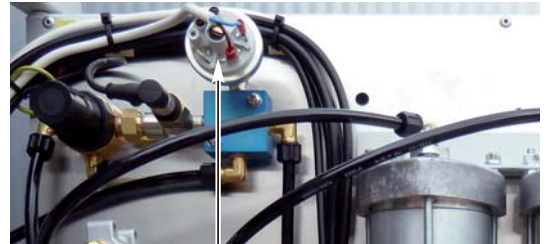

38

### Set the switch values



**Deadly risk!**

**Switch off operating voltage!**

- Turn the setting screw (43) of the pressure switch in the required direction (see setting options).
- Turn on main switch again.

### Setting options of screw (43)

Turn to the **right**: Switchpoint **increases**

Turn to the **left**: Switchpoint **drops**

**Changes affect switchpoint and rear switchpoint similarly.**

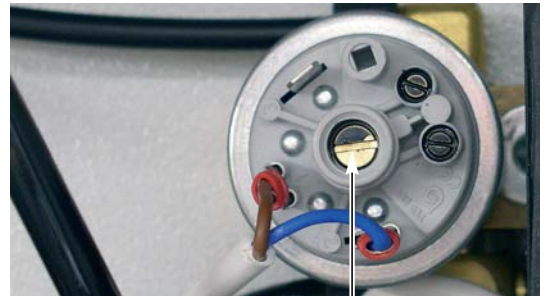

43

### Restore operating status

- Close safety valve "high pressure" (18).
- Set pressure reducer (14) to cable pressure (see the following chapter).



## Check and set pressure monitor



### Deadly risk!

### Working on open, live equipment!

- Do not operate the equipment with damp hands!
- Caution: live components!

### Setpoint value switching pressure

compressors    **On** = 3.5 bar  
                       **Off** = 5.0 bar

### Check switch values

- Switch on operating voltage.
- Close shut-off valve (15).
- Open safety valve "high pressure" (18) and observe manometer "high pressure" (10).
  - with a pressure drop below **3.0 bar** both compressors must start.
- Close safety valve "high pressure" (18) and observe manometer "high pressure" (10).
  - with a pressure increase to **5.0 bar** and furthermore both compressors must switch off.

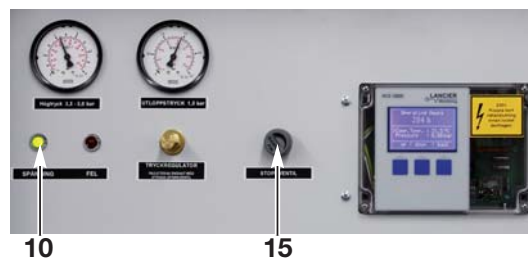

### To set the switch values note the following:

- Only set pressure monitor (31) under pressure!
- Rotating the hand valve (87) causes approx. 0.6 bar change of switching pressure.
- First set the cut-out pressure and then the cut-in pressure, because changing the cut-out pressure leads to a change in the cut-in pressure. This means the difference between cut-out and cut-in pressure stays the same.
- Once the hand valve has been pressed down (87) the cut-in pressure can be adjusted separately and the difference between the cut-out and cut-in pressure changed.

### Set the switch values

- Lift up the plastic cover of the pressure monitor after unfastening the four screws.
- Unscrew the lock pin (88) of the hand valve (87).

### Set the cut-out pressure:

#### Raise cut-out pressure

- Turn hand valve (87) clockwise (pressure +)

#### Lower cut-out pressure

- Turn hand valve (87) anti-clockwise (pressure -)

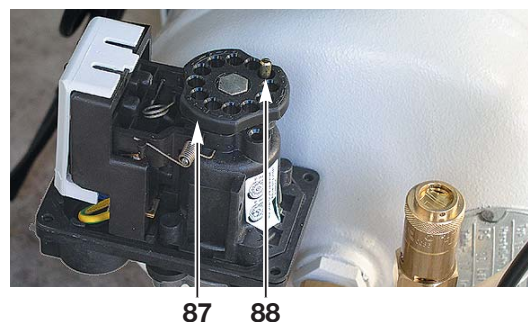

### Set the cut-in pressure:

#### Raise cut-in pressure

- Press down hand valve (87) and then turn clockwise (difference -)

#### Lower cut-in pressure

- Press down hand valve (87) and then turn anti-clockwise (difference +)



### After setting

- Screw in lock pin (88) in one of the two retainers.
- Put on the cover of the pressure monitor again and tighten.

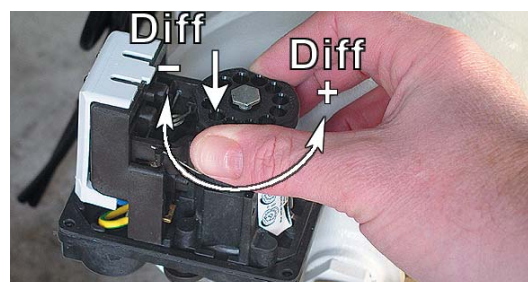



## Check and set pressure limiting valve



**Deadly risk!**

**Working on open, live equipment!**

- Do not operate the equipment with damp hands!
- Caution: live components!

Setpoint value opening pressure = 5.5 bar

Accomplish settings at operating temperature (warm equipment) only!



**Risk of damage!**

Dryer and humidity shut-off work reliably only, if the pressure limiting valve (34) is set properly.

### Check opening pressure



**Deadly risk!**

**Switch off operating voltage!**



**Risk of injury!**

Prior to operation, depressurise the equipment by opening the safety valve "high pressure" (37)!

- Unscrew blind cover (89) from the pressure limiting valve (29).
- Unfasten hose connection from the manometer "high pressure" (10):
  - unscrew connecting nut.
  - pull out hose.
- Connect the supplied testing hose to the pressure limiting valve (29) and the manometer "high pressure" (10) (so the manometer "high pressure" (10) can be used as a test gauge).
- Close safety valve "high pressure" (18).
- Switch on operating voltage
  - The manometer "high pressure" (10) must increase by  $5.5 \pm 0.1$  bar.

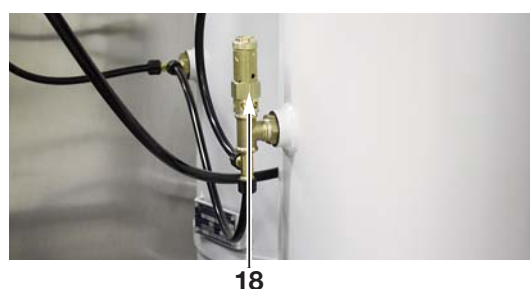
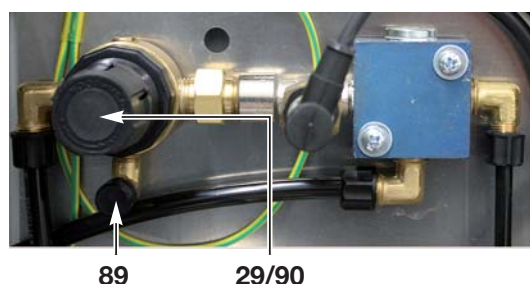

**otherwise:**

### Set setpoint value opening pressure of pressure limiting valve

- Pull setting knob (90) back and turn until the manometer "high pressure" (10) displays the setpoint value.
- Press on the setting knob (90) again and allow it to lock into place.

### Restore operating status

- Switch off operating voltage!
- Depressurise the equipment by opening the safety valve "high pressure" (18)!
- Remove testing hose.
- Insert hose on manometer "high pressure" (10) again and screw in tightly.
- Screw on blind cover (89) on the pressure limiting valve (29).
- Close safety valve "high pressure" (18).
- Switch on operating voltage again
- Check all threaded hose coupling for impermeability.

## Check humidity monitoring



### Deadly risk!

#### Working on open, live equipment!

- Do not operate the equipment with damp hands!
- Caution: live components!

## Check switching function



### Deadly risk!

#### Switch off operating voltage!



### Risk of injury!

#### Prior to operation, depressurise the equipment by opening the safety valve "high pressure" (18)!

#### The air dryers must be bypassed for this operation.

- Close shut-off valve (15) at the instrument panel (2).
- Unscrew cap nut of the sealing plug (126) at the T-piece (125) and remove sealing plug (126).
- Unscrew cap nut of the air hose (127) leading from the cyclone water separator (26) to the solenoid valve Y1 (25) at the solenoid valve.
- Connect air hose (127) to T-piece (125) and fix it with its cap nut.
- Close the open connector of the solenoid valve Y1 (25) with sealing plug (126) and fix it with its cap nut.
- Open safety valve "high pressure" (18) and discharge tank. Close safety valve "high pressure" (18) after this.
- Switch on operating voltage:
- after a few minutes the red signal-LED „F“ (48) illuminates on the MFR (73) and the system will be shut down and
- the red Signal output-LED „A“ (64) illuminates on the MFR.
- If the humidity shut-down process is not executed, discharge tank again by opening safety valve "high pressure" (18), in order to start a new compressor run.
- Close safety valve "high pressure" (18) again.

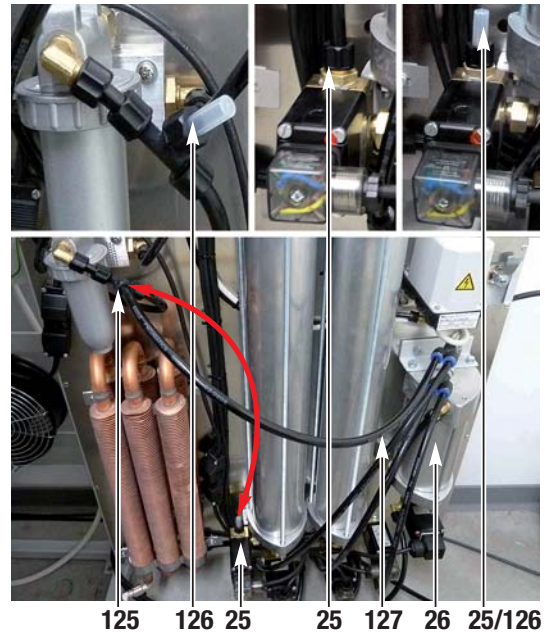

## Restore operating status



### Deadly risk!

#### Switch off operating voltage!



### Risk of injury!

#### Prior to operation, depressurise the equipment by opening the safety valve "high pressure" (18)!

- Re-establish air hose (127) and sealing plug (126) to their original position and fix them tightly with their cap nuts.
- Switch on operating voltage.

## If the compressors fail to start, allow the equipment to "run dry":



### Deadly risk!

#### Electro specialists only are allowed to operate the buttons of the MFR. Other users have to use the ACS device (16).

- Open safety valve "high pressure" (18).
- Press button „F-Off“ (67) on the MFR (36) or ACS (16).
- The compressors start.
- The red LED „A“ (64) on the MFR turned off.
- The green Signal-LED „F-on“ (54) in the MFR is turned off = no humidity monitoring.
- The red Signal-LED „F“ (48) illuminates in the MFR = pressurised air humidity is unadmissibly high.



18

## After a while

- The red Signal-LED „F“ (48) on the MFR turns off = the pressurised air is dry.
- The green Signal-LED „F-on“ (54) on the MFR is still turned off = no humidity monitoring.

**Warning!**

Pressing the button „F-off“ overrides the humidity monitoring.

The button must be used only, if a fault occurred, the „high pressure“ safety valve (18) is open and the shut-off valve "cable pressure" (15) is shut.

Humidity monitoring must be reactivated immediately after trouble-shooting, to assure proper function of the pressurisation equipment.

In order to get immediate humidity monitoring, the "F-off" operation must be overridden:

- Press button „F-Off“ (67) of the MFR or of the ACS for approx. 5 seconds.
- The green LEDs „F-On“ (54) on the MFR illuminate again.
- Close safety valve "high pressure" (18).
- Then carry out function testing.

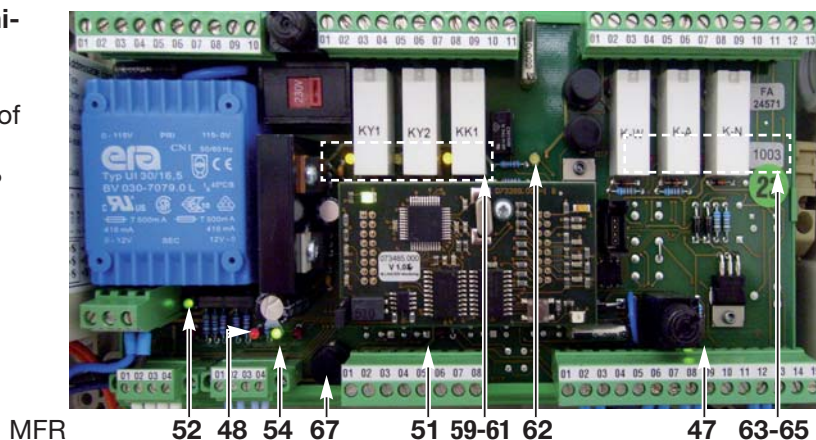

The humidity monitoring activates itself automatically after approx. 2 operating hours of the compressor, if the „F-off“ operator is not determined manually.

Switching the motor protective switch (33) off and on again, terminates the „F-off“ operation also. This procedure resets the MFR by breaking its power supply.

**After the function testing****Deadly risk!**

Switch off operating voltage!

**Check clock pulse air dryer change-over****Deadly risk!**

Working on open, live equipment!

- Do not operate the equipment with damp hands!
- Caution: live components!

**Setpoint value**

The clock pulse of the air dryer change-over is system-dependent factory preset in the MFR (36):

- 120 s ± 10 %

**Check clock pulse**

- Switch on operating voltage.
- Open safety valve "high pressure" (18).
- The compressors (6) must run.
- Measure clock pulse.

The MFR (36) controls the solenoid valves of the air dryer in the clock pulse regarding the compressor run time. The change of the valves is visualised by the LEDs „Y1-State“ (59) and „Y2-State“ (60) on the MFR and audible by the sudden escape of regeneration air into the condensate surge hose (9).

**Set clock pulse**

- The clock pulse is factory preset and can be altered by the manufacturer only.

## Check humidity content of output air

The humidity content of the output air should be measured with a stand-alone humidity analyser from time to time to detect insufficient working humidity sensors of the pressurisation system.

We recommend the digital humidity analyser DFP from LANCIER Monitoring, order-no. 072773.000.



## Operation On - Off



**Deadly risk!**

**Do not operate the equipment with damp hands!  
Take caution with live components!**



**Risk of injury!**

**Take caution with heated components!**

## Connection equipment pneumatics

- Switch off operating voltage!
- Close shut-off valve **(15)** at the instrument panel **(2)**.
- Establish pneumatic connection to pressurised air consumers.



**15**

## Pneumatic connection to air consumers

- Connect pressurised air consumers to the equipment output **(7)** at the equipments back side with a R¼” screwed coupling and pressure hose.



**7**

## Normal mode

- Switch on operating voltage.
- Wait until the equipment is charged.
  - The compressors switches off at 5.0 bar.
- Open shut-off valve **(15)**,
  - the compressors automatically switch on and off when reaching the lower and upper pressure values.





## Emergency mode

If, during maintenance or repair works, the connected pressurised air consumer must continue to be supplied with pressurised air, a mobile pressurisation equipment (e.g. series LAM, adjusted to approx. 1.5 bar cable pressure) can be connected to the pressurised air consumers.



**Deadly risk!**  
Switch off operating voltage!



**Risk of injury!**  
Prior to operation, depressurise the equipment by opening the safety valve "high pressure" (15)!

- Switch off operating voltage or pull out the mains plug!
- Close shut-off valve (15) of stationary system.
- Depressurise the equipment by opening the safety valve "high pressure" (15).
- Remove the pressure hose of the compressed air consumers from equipment output (7) at the equipments back side.
- Attach pressure hose of the compressed air consumers to the equipment output of the mobile system.
- Set mobile system into operation while observing the respective instruction manual and safety instructions.



## Shut down operation

- Switch off operating voltage!
- Turn off both motor protective switches (33).
- Remove connecting hoses from the equipment output (7).
- Depressurise equipment!
  - Open shut-off valve (15) for this.
- Close shut-off valve (15) again.
- If necessary, branch off electrical connections.

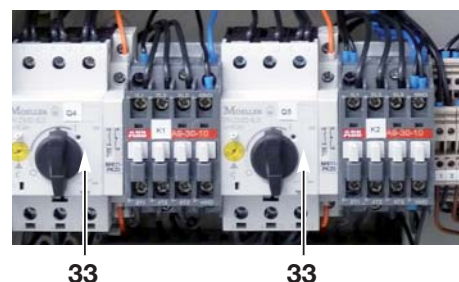



## Servicing

### General comments

- Follow the maintenance guidelines and intervals accurately, so that the equipment stays in sound operating condition.
- The terms specified for maintenance intervals must be adhered to!
- Maintenance works may only be carried out by skilled personnel!
- Test air storage tank regularly in accordance with the regulation on pressure tanks!
- Allow system testing to be carried out regularly in accordance with DIN/VDE 0701/0702, BGV A2 (this testing can also be commissioned at LANCIER-Monitoring).
- Only use original LANCIER Monitoring replacement parts!
- After maintenance works tighten all loosened screw joints again!
- The individual operating elements (**figures in brackets**) are described in full in the preceding chapters and are no longer illustrated here

## Maintenance

### Cleaning or changing compressor air intake filters



**Deadly risk!**

**Working on open, live equipment!**

- Do not operate the equipment with damp hands!
- Caution: live components!



**Deadly risk!**

**Switch off operating voltage!**



**Risk of injury!**

**Caution with heated components!**



**Risk of injury!**

**Wear protective goggles when blowing out devices.**

- Switch off operating voltage!
- Turn and pull filter cap (93) to the left (anti-clockwise).
- Pull out filter cartridge (94) and then blow with pressurised air.
- Renew filter cartridge (94) in the case of heavy contamination or damage.
- Insert filter cartridge (94) in the center of the housing.
- Put on filter cap (93) and turn right (clockwise) until the marks face each other.
- Carry out maintenance works on the second air intake filter.
- Switch on operating voltage!

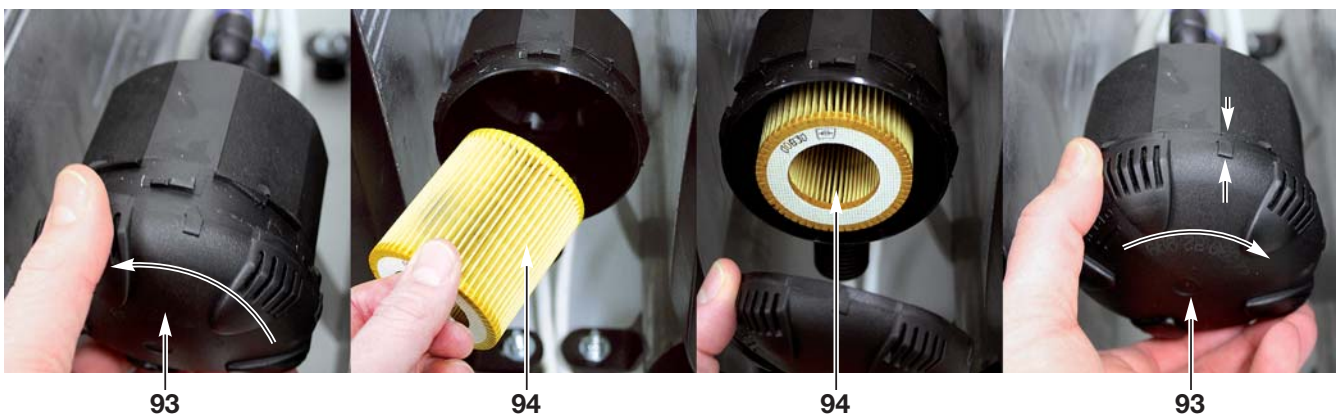

## Cleaning coolers for the compressor exhaust air



**Risk of injury!**  
Wear protective goggles when blowing out coolers.

- Open side door (8).
- Blow out soiled coolers (23) with compressed air.
- Close side door (8).



23

## Change micro filter element of micro filter



**Deadly risk!**  
Switch off operating voltage!



**Risk of injury!**  
Prior to operation, depressurise the equipment by opening the safety valve „high pressure“ (18)!

### Change micro filter element (99) of micro filter (28)

- when the UMS monitoring system indicates that the compressors pressure is reaching the maximum admissible limit,
- after changing drying agent of the drying agent containers (24) (see page 42)

- Switch off operating voltage!
- Open side door (8).
- Close shut-off valve (15).
- Depressurise the equipment by opening the safety valve "high pressure" (18)!
- Detach micro filter:  
Remove filter cup (96) by loosening the connecting nut from the filter head (97).
- Unfasten hollow grub screw (98) with micro filter element (99).
- Remove micro filter element (99) and replace with new one.
- Clean seals (A), (B) and (C), if necessary replace worn seals.
- Cover hollow grub screw (98) with O-ring (C) and then with seal (A).
- Screw hollow grub screw (98) together with micro filter element (99) and seal (B) again into the filter head (97).
- Clean filter cup (96), keep dust-free.
- Attach filter cup (96) by tightening the connecting nut on the filter head (97).
- Close safety valve "high pressure" (18)
- Open shut-off valve (15).
- Close side door (8).
- Switch on operating voltage.

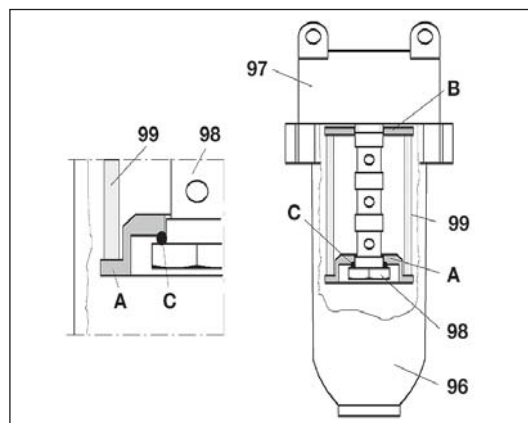

## Maintenance of air dryers



**Deadly risk!**  
Switch off operating voltage,  
Unscrew or disconnect back-up fuse!



**Risk of injury!**  
Prior to operation, depressurise the equipment by opening the safety valve „high pressure” (18)!



**Risk of injury!**  
Caution with heated components!

### Service air dryers (26)

when the UMS monitoring system indicates that the dew point is rising,

#### 1. Prepare equipment for servicing

- Switch off operating voltage!
- Open side door (8).
- Close shut-off valve (15).
- Depressurise the equipment by opening the safety valve "high pressure" (18)!

#### 2. Unscrew drying agent container (24)

- Unscrew all hose lines from the drying agent containers (24).
- Unscrew lower assembly bracket (102) with the drying agent containers (26) and take both out.

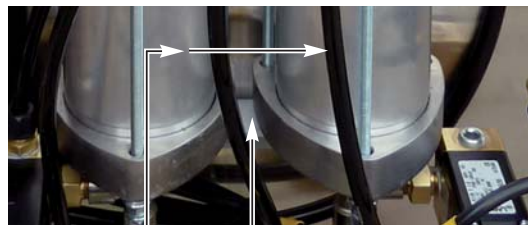

24 102

#### 3. Disassemble drying agent container



**Risk of injury!**  
Do not touch drying agent with wet hands, heat build-up!



**Risk of injury!**  
Wear safety glasses when working with drying agents.

- Unscrew nuts (D) of upper cover (E).
- Place drying agent container on the head.
- Remove lower cover (F) with the mounting bolts (G) from the cylinder tube (H).
- Pour out drying agent (I).
- Remove upper cover (E) from the cylinder tube (H) and take out pressure spring (J).
- Press out upper filter disc (K) with sealing ring (L).
- Take out o-rings (M), PE sealing rings (N + P) and filter cone (O) from the covers.



**Note for disposal!**  
Dispose of used drying agents in accordance with the regulations applicable in the country and site of use.

#### 4. Clean drying agent container

- Dry clean all parts
- Replace worn o-rings (M).
- Replace filter disc (L) and filter cone (O).
- Replace worn sealing rings (L) and (N + P).

#### 5. Assemble drying agent container

- Insert new filter cone (O), PE sealing rings (N + P) and O-rings (M) in the lower cover (F).
- Put cylinder tube (H) on the lower cover (F).

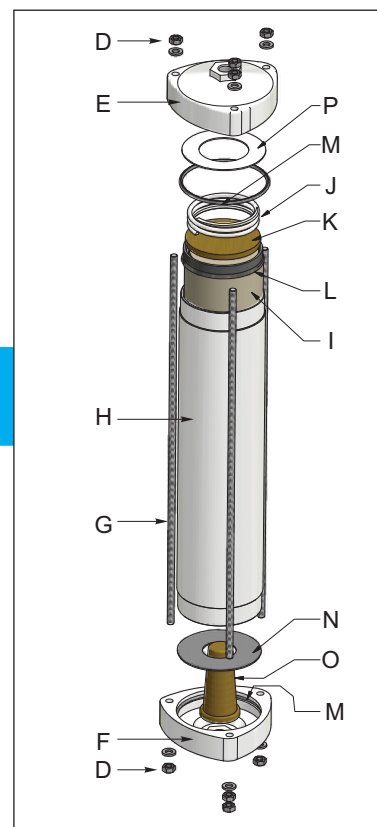

- Pour in new drying agent (molecular sieve) (I): approx. 1,500 g per drying agent container. Tap lightly on the cylinder tube with the shaft of a hammer, to avoid cavity formation.
- Insert new filter disc (K) with lubricated sealing ring (L) in the cylinder tube (H) and stand back from about 10mm (see fig.).
- Place pressure spring (J) on the filter disc (K).
- Place PE sealing ring (N) and O-ring (M) in the upper cover (E).
- Insert upper cover (E) on the cylinder tube (H) and tighten with the nuts (D) as much as possible.

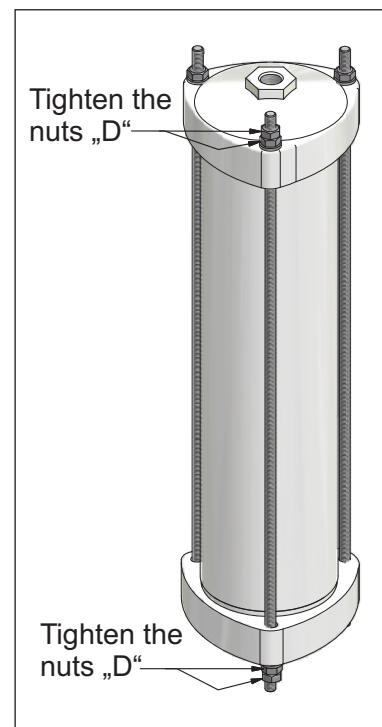

#### 6. Check solenoid valves

Check solenoid valves (25) for proper operation and replace them at least after 8000 operational hours.

#### 7. Remount drying agent container

- Insert and screw lower assembly bracket (102) with the drying agent containers (24) again on door panel of equipment.
- Screw all hose lines again onto the drying agent containers (24).

#### 8. Replace double non-return valve (30)

Spare part order no.: 074661.000

#### 9. Replace pressure limiting valve (29)

Spare part order no.: 029048.000

#### 10. Service Cyclone water separator

- Remove connecting hoses and solenoid valve (27).
- Dismantle assembly bracket (118) with the cyclone water separator (26) and take both out.
- Disassemble cyclone water separator (26).
- Clean cyclone water separator (26) and check for residues - especially at air intake
- Replace O-rings and grease them slightly.
- Re-assemble cyclone water separator (26).
- Re-mount cyclone water separator (26) with assembly bracket (118) into the system.
- Replace worn out braking element if necessary.
- Re-connect connecting hoses and solenoid valve (27) and check for switching ability.

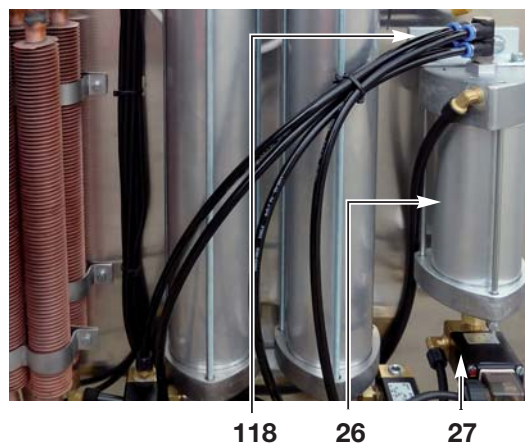

#### 11. For the following operation start up the equipment again:

- Connecting hose (7) is disconnected from air consumer.
- Close shut-off valve (15).
- Connect power supply.
- Turn both motor protective switches (33) to „I“.

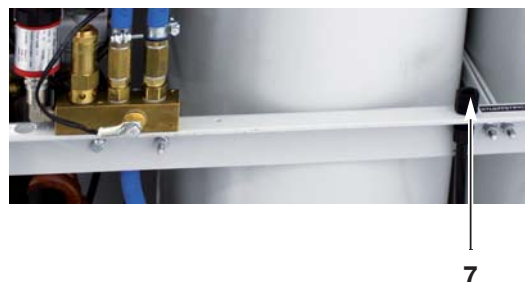

#### 12. Function testing

Carry out function testing, see pages 32 - 36.

#### 13. Test impermeability

Test all hose connections of the whole system for impermeability.

#### 14. After maintenance

- If necessary, re-establish connection to consumer load and open shut-off valve (15).
- Close side door (8).

## Causes and remedy of faults

Signal on site	Fault	Cause	Remedy
Green LED "Operating voltage" (12) does not illuminate.	Equipment does not receive operating voltage.	Operating voltage is not switched on. Input voltage is interrupted. Faulty wiring.	Switch on operating voltage. Test back-up fuse 16 A and connections. Test wiring.
	Motor protective switch (33) has disconnected compressor.	Motor protective switch (33) is set incorrectly. Compressor is getting too hot.  Compressor pressure is too high.  Compressor has an electric fault.	Set motor protective switch correctly, see page 32. Check fan and radiator for plugging and clear these components if necessary. Check wiring of fan. Check solenoid valves for proper operation. Check double non-return valve for plugging. Check pressure monitor settings (3.5-5.0), s. page 33. Check cooler for pneumatic permeability. Replace compressor.
	Primary voltage of MFR (36) is interrupted.	Microfuse „AC“ (A) is defective. Wiring of supply voltage of MFR is defective.	Replace microfuse „AC“ (A): Type M 0,315 A . Check wiring of MFR.
Red signal-LED „Fault“ (13) on the instrument panel (2) illuminates. Red Signal-LED „F“ (48) on the MFR (36) illuminates.	Humidity fault = relative humidity of output air is unadmissibly high.	Maintenance of air dryers (24) was not carried out. Pressure limiting valve (29) is set incorrectly or defective. Double non-return valve (30) is contaminated.  Double non-return valve's (30) piston is blocked.  Electric triggering of solenoid valves (25) of air dryers (24) fails or is in wrong clock pulse.  Solenoid valves (25) are defective or worn out.  Cyclone water separator (26) is contaminated, solenoid valve (27) of separator works faulty. Humidity sensor (32) of MFR is defective or wiring is faulty. Hoses for regeneration air between air dryers (24) and cyclone water separator (26) are clogged.	Carry out maintenance of air dryer, see page 42. Set pressure limiting valve properly, see page 34, replace if necessary. Check amount of regeneration air, clean or replace injectors, see page 43.  Carry out maintenance of double non-return valve, see page 43, replace if necessary. Check cycle time, see page 32. Watch relay KY1 u. KY2, check wiring and plugs of solenoid valves. Check solenoid valves and replace if necessary.  Clean cyclone water separator, check wiring, plugs and solenoid valve, replace solenoid valve if necessary. Check wiring, replace humidity sensor if necessary. Clean or replace hoses.
Red signal-LED „Fault“ (13) on the instrument panel (2) illuminates. Red Signal-LED „F“ (48) on the MFR (36) flashes.	Humidity fault = either the electrical connection to the humidity sensor or the humidity sensor (32) itself is broken.	The electrical connection to the humidity sensor is broken.  The humidity sensor (32) is broken.	Check electrical connection cable to the humidity sensor, replace cable if necessary.  Check functionality of the humidity sensor (32) (see page 37), replace sensor if necessary.



## What to do after "humidity fault"?

The MFR (36) switched off the compressors (6), the humidity of the output air is inadmissibly high.

- The red signal-LED „F“ (48) illuminates on the MFR and the red signal-LED „Fault“ (13) on the instrument panel (2) illuminates.
- The red signal output-LED „A“ (63) illuminates on the MFR
- The ACS shows a humidity value of the output air that is inadmissible high (> 4%).

### Search for faults, remedy faults

#### 1. Shut down operation

(see page 38).

- Open cabinet door
- Switch off operating voltage.
- Disconnect electrical power or switch main switch off!
- Depressurise equipment!
  - Open safety valve "high pressure" (15) for this.
- Close safety valve "high pressure" (15).

#### 2. Search for and remedy faults

according to charts "Causes and remedying of faults", page 44.

#### 3. Restart equipment and allow to run dry

see page 31.



**Deadly risk!**

**Do not operate the equipment with damp hands!**

**Caution with live components!**



**Risk of injury!**

**Caution with heated components!**

### Normal mode

see page 30.

- Switch on operating voltage.
- Wait until the equipment is charged.
  - Signal-LED „F“ (48) on the MFR (36) turns off.
  - The compressors switch off at 5.0 bar.
- Open shut-off valve (15) and if necessary, shut-off valves (option) of pressurised air consumer,
  - the compressors automatically switch on and off when reaching the lower and upper pressure values.
- Close cabinet door.

If the compressors fail to start, allow the equipment to "run dry":



**Deadly risk!**

Electro specialists only are allowed to operate the buttons of the MFR.  
Other users have to use the ACS device (16).

- Open safety valve "high pressure" (18).
- Press button „F-Off“ (67) on the MFR (36) or ACS (16).
- The compressors start.
- The red LED „A“ (64) on the MFR turned off.
- The green Signal-LED „F-on“ (54) in the MFR is turned off = no humidity monitoring.
- The red Signal-LED „F“ (48) illuminates in the MFR = pressurised air humidity is unadmissibly high.



18

**After a while**

- The red Signal-LED „F“ (48) on the MFR turns off = the pressurised air is dry.
- The green Signal-LED „F-on“ (54) on the MFR is still turned off = no humidity monitoring.



**Warning!**

Pressing the button „F-off“ overrides the humidity monitoring.  
The button must be used only, if a fault occurred, the „high pressure“ safety valve (18) is open and the shut-off valve "cable pressure" (15) is shut.  
Humidity monitoring must be reactivated immediately after trouble-shooting, to assure proper function of the pressurisation equipment.

In order to get immediate humidity monitoring, the "F-off" operation must be overridden:

- Press button „F-Off“ (67) of the MFR or of the ACS for approx. 5 seconds.
- The green LEDs „F-On“ (54) on the MFR illuminate again.
- Close safety valve "high pressure" (18).
- Then carry out function testing.

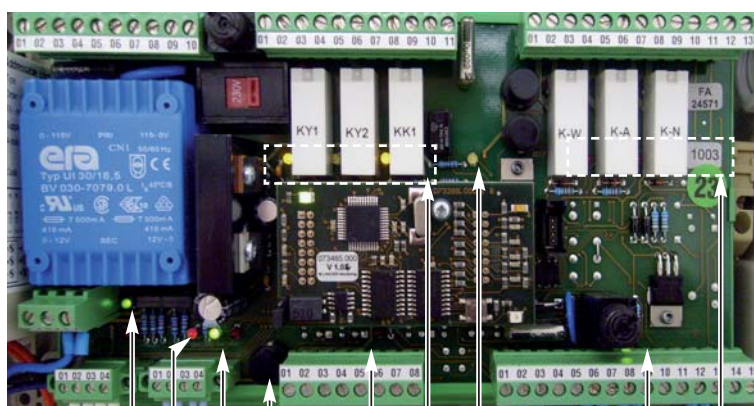

MFR

52

48

54

67

51

59-61

62

47

63-65

The humidity monitoring activates itself automatically after approx. 2 operating hours of the compressor, if the „F-off“ operation is not determined manually.

Switching the motor protective switch (33) off and on again, terminates the „F-off“ operation also. This procedure resets the MFR by breaking its power supply.



## Replacement parts

### Display, operation

Item	Name	Order no.
1	4000 h-Service packet for pneumatic system without compressors	074669.000
2	Manometer 0 - 2.5 bar	051205.000
3	Manometer 0 - 10 bar	048965.000
4	Pressure reducer	023385.000
5	Shut-off valve	019801.000
6	Label replacement Svensk compl.	073901.100
7	Pressure monitor	006464.000
8	Non-return valve	053093.000
9	Safety valve "cable pressure" 1.7 bar	056716.000
10	Humidity sensor MFR	073351.000
11	Pressure limiting valve	029048.000
12	ACS addressable compressor monitoring unit	072891.110
13	Door lock (no illustration)	040691.000
14	Rubber/metal oscillating buffer for compressors (no illustration)	016356.000
15	Compressor hose	074515.000
16	Fan	022343.000
17	Cooler for compressor air	020076.000
18	Micro filter element, see page 51 also	057412.000
19	Solenoid valve 3/2 way (when ordering replacement part specify voltage and frequency!)	031538.000
20	Double non-return valve	074661.000
21	Safety valve "high pressure" at air storage tank (when ordering replacement part specify cable pressure!)	023791.000
22	Pressure sensor "compressor pressure" for ACS device	073153.000
23	Safety valve "compressor"	023791.000
24	Backpressure valve "compressor"	022075.000
25	Temperature sensor "compressor temperature" for ACS device	073155.100
26	Pressure switch „High pressure alarm”	074699.000
27	PE hose 6/4	006827.000
28	PA hose 8/6	018499.000
29	PA hose 10/8	027259.000

The components on this page marked with "\*" are an integral part of the service package named on page 48.

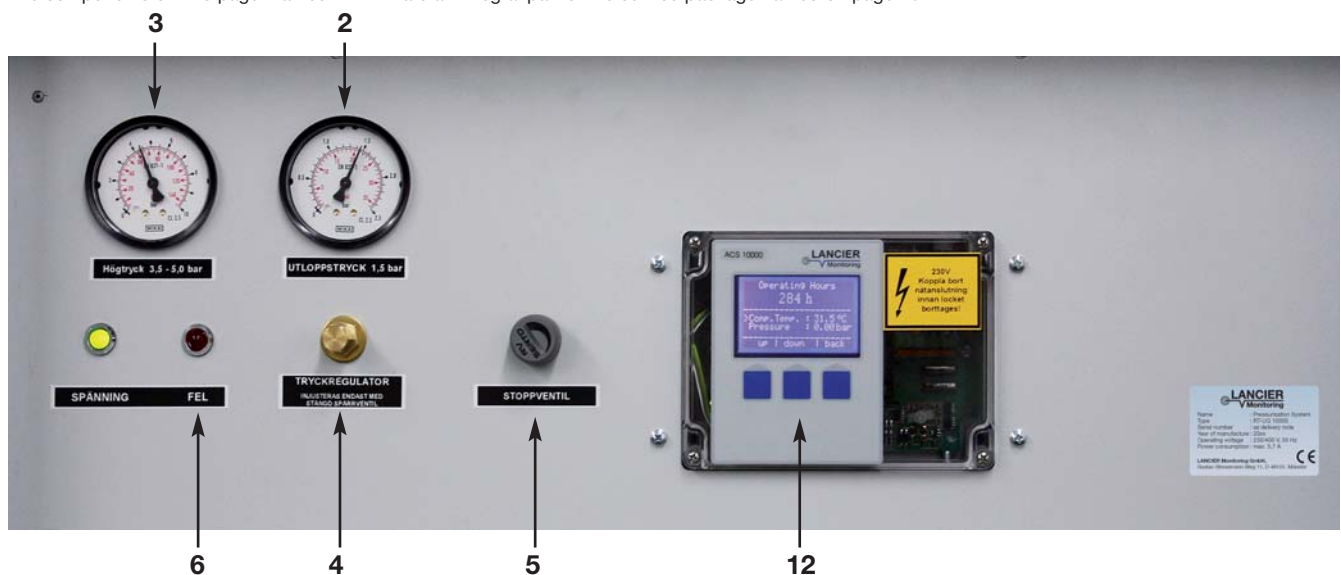

Back of instrument panel

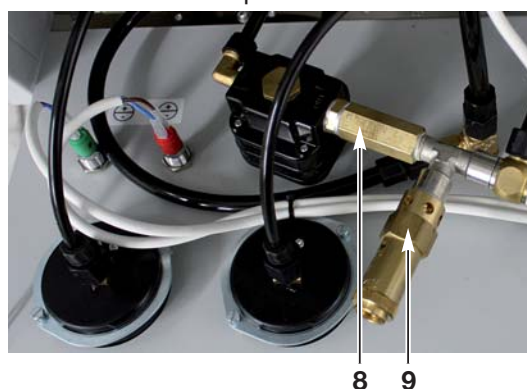

Interior

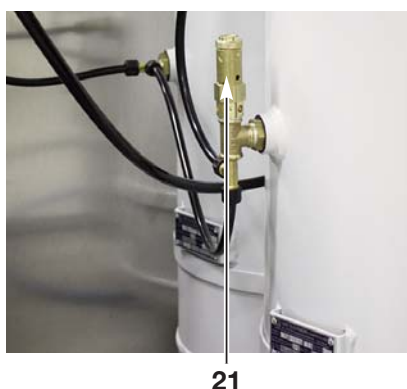

Back of equipment

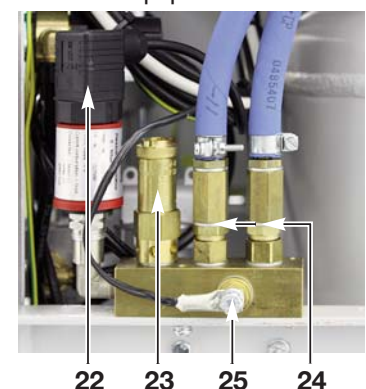







## Drying agent container

Item	Name	Order no.
	Drying agent container compl. (24)	074668.000
I*	Molecular sieve for 2 containers: 2,25 kg + 1 kg	064786.000 + 022528.000
M*	O-Ring	002792.000
K*	Upper filter disc	056714.000
L*	Sealing ring for upper filter disc	056715.000
O*	Bottom filter cone	017259.000
P*	Sealing ring top	004173.000
N*	Sealing ring bottom	017260.000

The components on this page marked with "\*" are an integral part of the service package named on page 48.

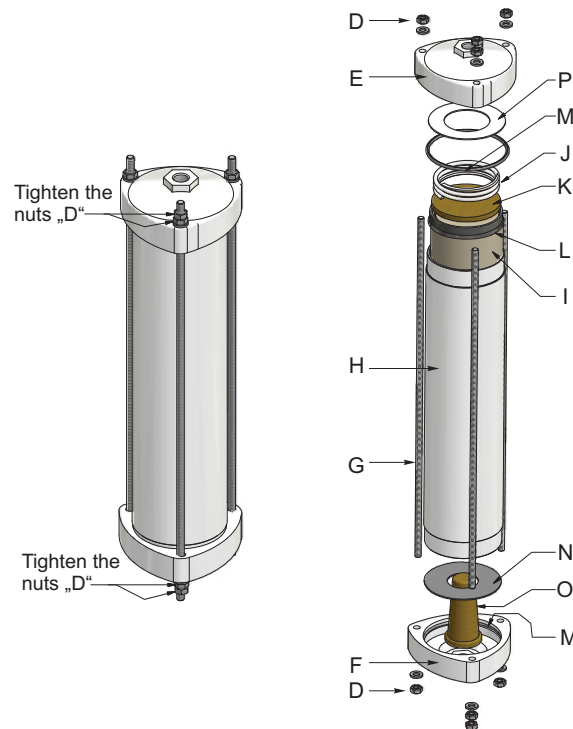

## Compressor PK 145/2

Item	Name	Order no.
	PK 145/2 compl. (6)	074608.000
1	Intake filter	073871.000
2	Filter cartridge	073872.000

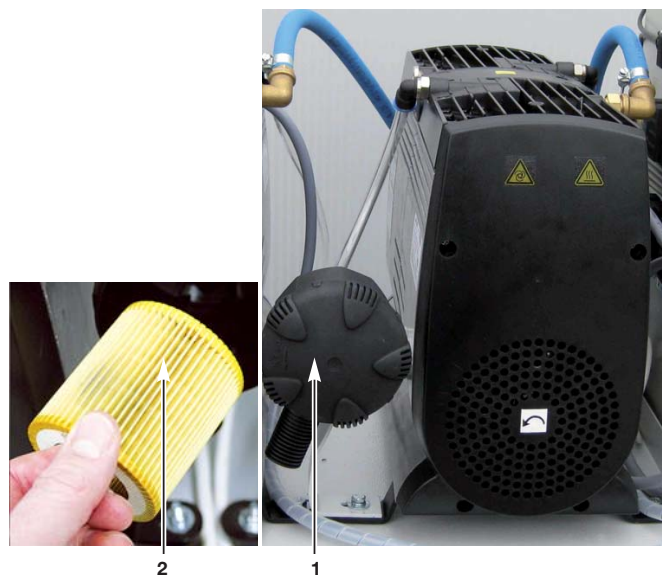

## Micro filter

Item	Name	Order no.
	Micro filter compl. (33)	057411.000
1*	Micro filter element (96)	057412.000
2	Seal (97) (B)	056360.000
C	O-Ring (C)	034390.000

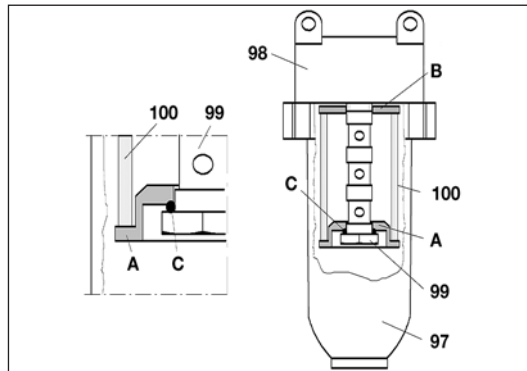

## Electrics

Item	Name	Order no.
1	Auxiliary switch of motor protective switch [Q4]	067955.000
2	Motor contactor / switch [K1]	073610.000
3	Motor protective switch [Q4] and [Q5]	067952.000
4	Multifunktional relay MFR	073285.001
5	Sensor CDtA	073985.000

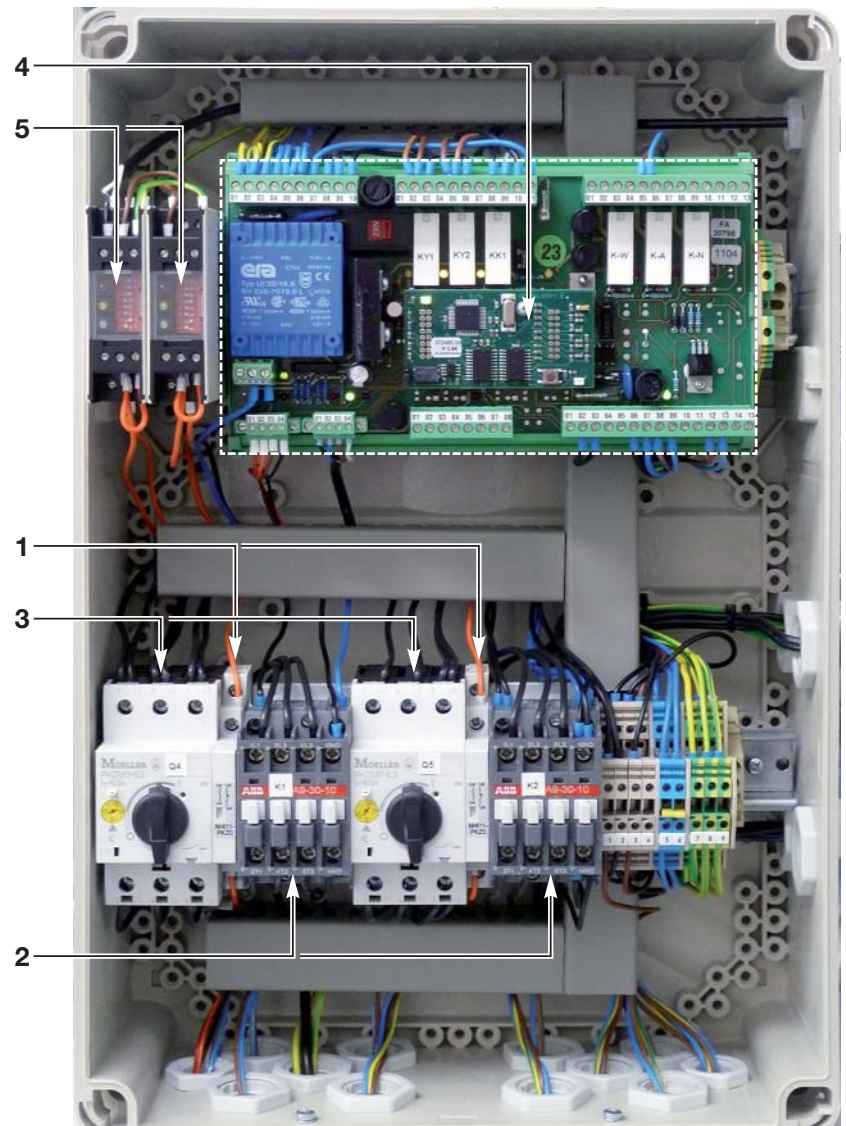

## Plans

### Equipment lists pneumatics RT-UG 5000

- |   |  |
|---|--|
| 1.1 Intake filter 1                     | 12.1 Pressure reducer "Cable pressure" 1       |
| 1.2 Intake filter 2                     | 12.2 Pressure reducer "Cable pressure" 2       |
| 1.3 Intake filter 3                     | 12.3 Pressure reducer "Interim pressure"       |
| 1.5 Micro filter 1                      |  |
| 1.6 Micro filter 2                      |  |
|   | 13.1 Shut-off valve "Cable pressure" 1         |
| 2.1 Compressor 1                        | 13.2 Shut-off valve "Cable pressure" 2         |
| 2.2 Compressor 2                        | 13.3 Shut-off valve "High-pressure"            |
| 2.3 Compressor 3                        | 13.4 Shut-off valve "Kondensat"                |
| 2.4 Compressor with I.C.-engine         | 13.5 3/2 way mini valve 1                      |
|   | 13.6 3/2 way mini valve 2                      |
|   | 13.7 Shut-off valve "Interim pressure"         |
|   | 13.8 Shut-off valve of cable connection        |
| 3.1 Cooling coil 1                      |  |
| 3.2 Cooling coil 2                      |  |
| 3.3 Cooling coil 3                      |  |
|   | 14.1 Nozzle - output air „cable pressure“ 1    |
| 4.1 Non-return valve 1                  | 14.2 Nozzle - output air „cable pressure“ 2    |
| 4.2 Non-return valve 2                  | 14.3 Nozzle - output air „high-pressure“       |
| 4.3 Non-return valve 3                  | 14.4 Pneumatic resistor                        |
|   | 14.5 Injector "Aeration"                       |
|   |  |
| 5.1 Drying agent container - Dryer 1    | 15.1 Total air flow meter "Cable pressure" (1) |
| 5.2 Drying agent container - Dryer 2    | 15.2 Air flow meter                            |
| 5.3 Drying agent container - Dryer 3    | 15.3 Air flow meter regenerated air            |
|   |  |
| 6.1 Double non-return valve 1           | 16.1 Inspection glass                          |
| 6.2 Double non-return valve 2           |  |
| 6.3 Double non-return valve 3           | 17 Condensate surge tank                       |
|   |  |
| 7.1 Testing valve "cable pressure" 1    | 18.1 Hose coupling "Cable pressure"            |
| 7.2 Testing valve "cable pressure" 2    | 18.2 Hose coupling "High-pressure"             |
| 7.3 Flange of test manometer            | 18.3 Connection "Double equipment"             |
|   | 18.4 Connection "Pressure transducer" 1        |
| 8.1 Pressure limiting valve 1           | 18.5 Connection "Pressure transducer" 2        |
| 8.2 Pressure limiting valve 2           | 18.6 Connection "Test manometer"               |
| 8.3 Pressure limiting valve 3           |  |
|   | 19.1 Connecting hose                           |
| 9.1 Air storage tank 1                  |  |
| 9.2 Air storage tank 2                  | 20.1 Cyclone separator                         |
| 9.3 Air storage tank 3                  | 20.2 Cyclone-, water- and oil separator        |
| 9.4 Reserve air storage tank            |  |
|   | 21.1 Distributing regulator                    |
| 10.1 Safety valve "compressor" 1        |  |
| 10.2 Safety valve "compressor" 2        | 22.1 Charcoal filter                           |
| 10.3 Safety valve "compressor" 3        | 22.2 Adsorber                                  |
| 10.4 Safety valve "high pressure"       |  |
| 10.5 Safety valve "cable pressure" 1    |  |
| 10.6 Safety valve "cable pressure" 2    |  |
| 10.7 Safety valve "Interim pressure"    |  |
|   |  |
| 11.1 Manometer "High-pressure"          |  |
| 11.2 Manometer "Cable pressure" 1       |  |
| 11.3 Manometer "Cable pressure" 2       |  |
| 11.4 Manometer "Interim pressure"       |  |
| 11.5 Contact manometer "High-pressure"  |  |
| 11.6 Contact manometer "Cable pressure" |  |

## Pneumatics diagram RT-UG 5000, no. 074664.000

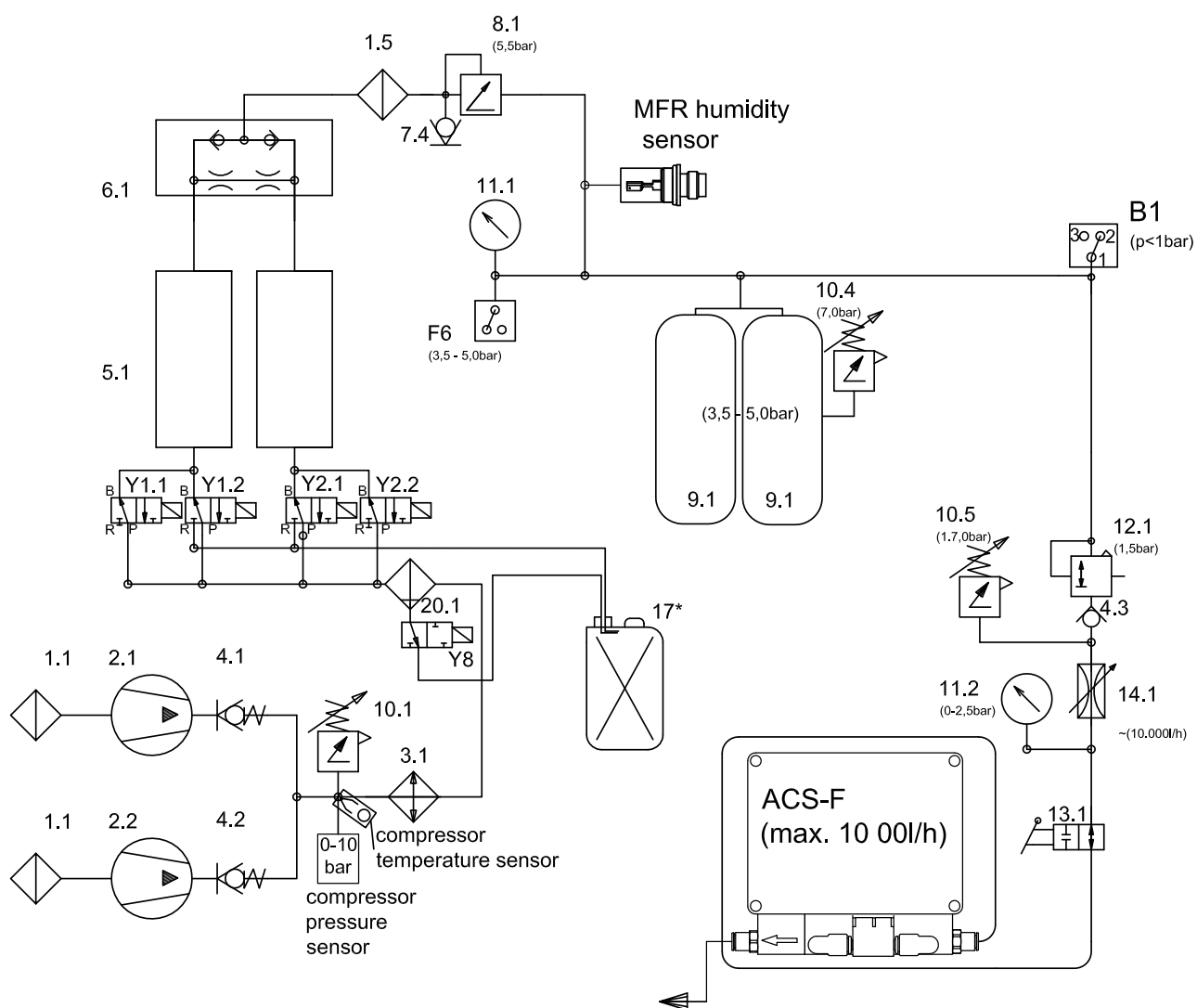

\* = option

## Equipment list electrics RT-UG 5000

A1	Humidity monitoring unit 1	M1	Motor - Compressor 1
A2	Humidity monitoring unit 2	M2	Motor - Compressor 2
A3	Humidity monitoring unit 3	M3	Motor - Compressor 3
A4	Control unit	M4	I.C.-engine
A5	Flow meter - Printed circuit board RTS		
A6	Flow meter - Integral part		
		P1	Counter of operation hours - Compressor 1
B1	Pressure switch "high pressure"	P2	Counter of operation hours - Compressor 2
B2	Pressure switch "Cable pressure (1) too low"	P3	Counter of operation hours - Compressor 3
B3	Pressure switch "Cable pressure (1) too high"	P4	Hygrometer 1
B4	Pressure switch "Cable pressure 2 too low"	P5	Hygrometer 2
B5	Pressure switch "Cable pressure 2 too high"	P6	Hygrometer 3
B6	Pressure switch "Add compressor 2"	P7	Counter of operation hours 1 with maintenance signal
		P8	Counter of operation hours 2 with maintenance signal
C1	Capacitor	P9	Counter of operation hours 3 with maintenance signal
		P10	Voltmeter
E1	Fan 1	Q1	Main switch AC
E2	Fan 2	Q2	Main switch DC
E3	Fan 3	Q3	Fused DC main switch DC
		Q4	Motor protective switch 1
F1	Motor protective relay 1	Q5	motor protective switch 2
F2	Motor protective relay 2	Q6	motor protective switch 3
F3	Motor protective relay 3		
F4	Thermal protection	S1	Programme switch 1
F6	Pressure monitor	S2	Programme switch 2
F7	Fuse	S3	Programme switch 3
F8	Overvoltage suppressor	S4	Switch "F-aus" 1
		S5	Switch "F-aus" 2
G1	Power pack 1	S6	Switch "F-aus" 3
G2	Power pack 2	S7	Change-over switch
G3	Power pack 3	S8	Door switch
G4	Battery	S9	Key "W-Test"
G5	Battery charger		
G6	Bridge rectifier	V	Diode
H1	Signal-LED "AC"	X1	Connecting block 1
H2	Signal-LED "DC"	X2	Connecting block 2
H3	Signal-LED "F"	X3	Connecting block 3
H4	Signal-LED "H"	X4	Connecting block 4
H5	Signal-LED "M"	X5	Connecting block 5
H6	Signal-LED "T"	X6	Power socket
H7	Signal-LED "N" (or "N1")		
H8	Signal-LED "N2"	Y1	3/2 way solenoid valve - Dryer 1
H9	Signal-LED "W"	Y2	3/2 way solenoid valve - Dryer 2
H10	Signal-LED "K" (or "K1")	Y3	4/2 way solenoid valve - Dryer 1
H11	Signal-LED "K2"	Y4	4/2 way solenoid valve - Dryer 2
H12	Signal-LED "G"	Y6	Humidity stop solenoid valve
H13	Signal-LED "A"	Y7	Non-return solenoid valve block
H14	Signal-LED "Fault"	Y8	Solenoid valve - Aeration
H15	Signal-LED "Signal interruption"		
K1	Contactator - Compressor 1		Short symbol for signals
K2	Contactator - Compressor 2	AC	= Operation AC
K3	Contactator - Compressor 3	DC	= Operation DC
K4	Power failure relay AC	F	= Humidity
K5	Signal relay "K"	H	= High-pressure
K6	Humidity detector relay 1	M	= Compressor failure
K7	Humidity detector relay 2	T	= Running time
K8	Humidity detector relay 3	N (or N1)	= Cable pressure (1)
K9	Time relay "Running time"	N2	= Cable pressure 2
K10	Signal relay "T"	W	= Maintenance
K11	Signal relay "A"	A	= Fault
K12	Signal relay "F"	G	= Cable filled
K13	Signal relay "M"	K (or K1)	= Cable fault (1)
K14	Signal relay "H"	K2	= Cable fault 2
K15	Signal relay "N"	S	= Fuse
K16	Time relay "8 min" 1	V	= Power failure AC
K17	Time relay "8 min" 2		
K18	Switch clock		
K19	Switching relay		
K20	Signal relay "W"		
K21	Time relay "Backlash"		
K22	Switching relay		
K23	Signal relay "V"		



Circuit diagram RT-UG 5000, no. 074665.000

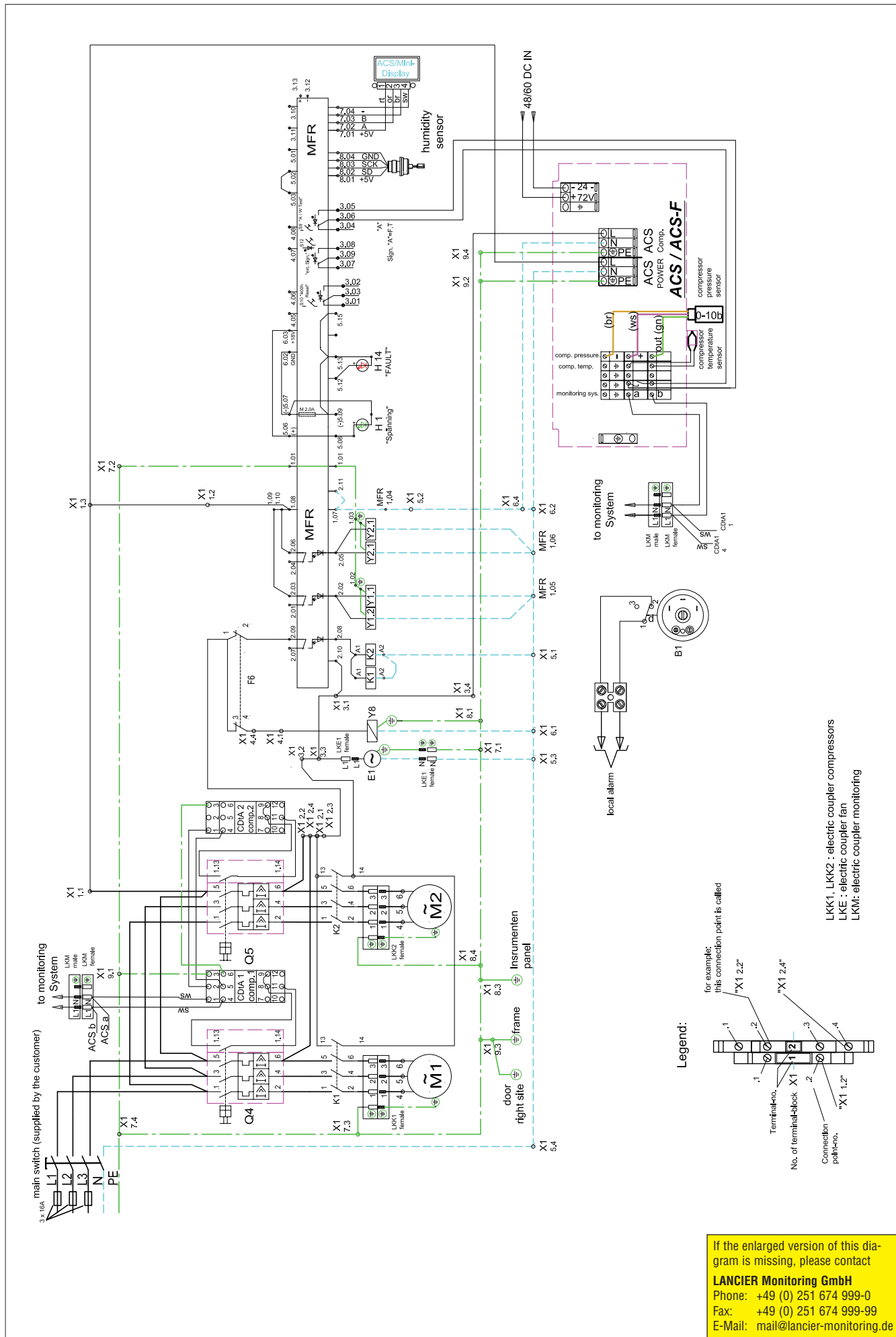

If the enlarged version of this diagram is missing, please contact  
**LANCIER Monitoring GmbH**  
 Phone: +49 (0) 251 674 999-0  
 Fax: +49 (0) 251 674 999-99  
 E-Mail: mail@lancier-monitoring.de

## Equipment list electrics RT-UG 5000

A1	Humidity monitoring unit 1	M1	Motor - Compressor 1
A2	Humidity monitoring unit 2	M2	Motor - Compressor 2
A3	Humidity monitoring unit 3	M3	Motor - Compressor 3
A4	Control unit	M4	I.C.-engine
A5	Flow meter - Printed circuit board RTS		
A6	Flow meter - Integral part		
		P1	Counter of operation hours - Compressor 1
B1	Pressure switch "high pressure"	P2	Counter of operation hours - Compressor 2
B2	Pressure switch "Cable pressure (1) too low"	P3	Counter of operation hours - Compressor 3
B3	Pressure switch "Cable pressure (1) too high"	P4	Hygrometer 1
B4	Pressure switch "Cable pressure 2 too low"	P5	Hygrometer 2
B5	Pressure switch "Cable pressure 2 too high"	P6	Hygrometer 3
B6	Pressure switch "Add compressor 2"	P7	Counter of operation hours 1 with maintenance signal
		P8	Counter of operation hours 2 with maintenance signal
C1	Capacitor	P9	Counter of operation hours 3 with maintenance signal
		P10	Voltmeter
E1	Fan 1	Q1	Main switch AC
E2	Fan 2	Q2	Main switch DC
E3	Fan 3	Q3	Fused DC main switch DC
		Q4	Motor protective switch 1
F1	Motor protective relay 1	Q5	motor protective switch 2
F2	Motor protective relay 2	Q6	motor protective switch 3
F3	Motor protective relay 3		
F4	Thermal protection	S1	Programme switch 1
F6	Pressure monitor	S2	Programme switch 2
F7	Fuse	S3	Programme switch 3
F8	Overvoltage suppressor	S4	Switch "F-aus" 1
		S5	Switch "F-aus" 2
G1	Power pack 1	S6	Switch "F-aus" 3
G2	Power pack 2	S7	Change-over switch
G3	Power pack 3	S8	Door switch
G4	Battery	S9	Key "W-Test"
G5	Battery charger		
G6	Bridge rectifier	V	Diode
H1	Signal-LED "AC"	X1	Connecting block 1
H2	Signal-LED "DC"	X2	Connecting block 2
H3	Signal-LED "F"	X3	Connecting block 3
H4	Signal-LED "H"	X4	Connecting block 4
H5	Signal-LED "M"	X5	Connecting block 5
H6	Signal-LED "T"	X6	Power socket
H7	Signal-LED "N" (or "N1")		
H8	Signal-LED "N2"	Y1	3/2 way solenoid valve - Dryer 1
H9	Signal-LED "W"	Y2	3/2 way solenoid valve - Dryer 2
H10	Signal-LED "K" (or "K1")	Y3	4/2 way solenoid valve - Dryer 1
H11	Signal-LED "K2"	Y4	4/2 way solenoid valve - Dryer 2
H12	Signal-LED "G"	Y6	Humidity stop solenoid valve
H13	Signal-LED "A"	Y7	Non-return solenoid valve block
H14	Signal-LED "Fault"	Y8	Solenoid valve - Aeration
H15	Signal-LED "Signal interruption"		
K1	Contactator - Compressor 1		Short symbol for signals
K2	Contactator - Compressor 2	AC	= Operation AC
K3	Contactator - Compressor 3	DC	= Operation DC
K4	Power failure relay AC	F	= Humidity
K5	Signal relay "K"	H	= High-pressure
K6	Humidity detector relay 1	M	= Compressor failure
K7	Humidity detector relay 2	T	= Running time
K8	Humidity detector relay 3	N (or N1)	= Cable pressure (1)
K9	Time relay "Running time"	N2	= Cable pressure 2
K10	Signal relay "T"	W	= Maintenance
K11	Signal relay "A"	A	= Fault
K12	Signal relay "F"	G	= Cable filled
K13	Signal relay "M"	K (or K1)	= Cable fault (1)
K14	Signal relay "H"	K2	= Cable fault 2
K15	Signal relay "N"	S	= Fuse
K16	Time relay "8 min" 1	V	= Power failure AC
K17	Time relay "8 min" 2		
K18	Switch clock		
K19	Switching relay		
K20	Signal relay "W"		
K21	Time relay "Backlash"		
K22	Switching relay		
K23	Signal relay "V"		



## Disposal

Disused LANCIER Monitoring pressurisation equipments must NOT be disposed as domestic waste or to the environment.

Please send the old depressurised system back to LANCIER Monitoring GmbH for professional recycling or disposal.

### **Contact:**

LANCIER Monitoring GmbH

Phone: +49 (0) 251 674 999-0

Fax: +49 (0) 251 674 999-99

E-Mail: [mail@lancier-monitoring.de](mailto:mail@lancier-monitoring.de)

### **Shipping address:**

LANCIER Monitoring GmbH

Gustav-Stresemann-Weg 11

48155 Münster

Germany

---





**LANCIER Monitoring GmbH**

Gustav-Stresemann-Weg 11  
48155 Münster, Germany

Tel. +49 (0) 251 674 999-0  
Fax+49 (0) 251 674 999-99

mail@lancier-monitoring.de  
www.lancier-monitoring.de

## EC Declaration of Conformity

We declare under our sole responsibility, that the product

**Make:** LANCIER Monitoring  
**Type:** Pressurization System RT-UG 5000

to which this declaration refers, meets the relevant health and safety requirements of the following EC directives:

<b>2006/42/EG</b>	<b>Machinery Directive</b>
<b>87/404/EWG</b>	<b>Simple pressure tanks</b>
<b>2006/95/EG</b>	<b>Low voltage directive</b>
<b>2004/108/EG</b>	<b>Electromagnetic compatibility</b>

For proper implementation of the health and safety requirements named in the EC directives the following standard(s) and/or technical specification(s) have been consulted:

<b>EN 12100-1 und 2</b>	<b>Machine safety</b>
<b>EN 286-1</b>	<b>Simple imitation pressure tank for air or nitrogen, part 1</b>
<b>EN 60204-1</b>	<b>Electrical fittings of machines</b>
<b>EN 61000-6-1</b>	<b>Interference resistance (fault-free operation)</b>
<b>EN 61000-6-3</b>	<b>Emitted interference</b>

The declaration loses its validity should any change be made to the parts delivered.

The special technical documents may be requested subject to justified requirement on the part of any government office:

Name: Ulrich Siebeneck

Address: see above

Data transmission is either electronic or on paper.

Münster, 20.08.2012

  
Research and Development

  
Managing Director